



**CAPE COD GATEWAY AIRPORT  
COMMISSION MINUTES OF THE REGULAR SESSION  
TUESDAY, October 19, 2021  
Via ZOOM**

The meeting was held at the Cape Cod Gateway Airport in the Airport Conference Room, 480 Barnstable Rd., Hyannis, MA and via ZOOM

**Commissioners Present:**

John T. Griffin, Jr., Chair; Elizabeth Young, Vice Chair; Norman Weill, Clerk; Wendy Bierwirth; John G. Flores; Bradley J. Bailey; and Joseph DiGeorge.

**Commissioners not present:**

**Yarmouth Representative:**

William Marasco was not present

**Airport Staff Present:**

Katie R. Servis, Airport Manager; Matt Elia, Assistant Airport Manager; Suzanne Kennedy, Executive Assistant to the Airport Manager; and Christina Lounsbury, Noise Abatement/Security Specialist

**Public Members:**

Robert Mallard, Airport Solutions Group; Christine Greeley, Hyannis Park Civic Association; Ned Dawes, Stantec; and Paul McDonough McFarland Johnson

**Call To Order:**

Chairman Griffin called the regular meeting of the Cape Cod Gateway Airport Commission to order at 4:00 p.m. Attendance roll call was taken followed by the Pledge of Allegiance.

**Minutes of the previous meetings:**

None - minutes have been delayed due to a temporary reduction in office staff

Chairman Griffin gave a few words in remembrance of former Commissioner Ron Pursitte and a moment of silence was held in his honor.

Manager Servis recognized employee Christopher Daniels. He will be moving to New Hampshire with his family and leaving the airport. He was thanked for his many years of service to the Airport.

**Public Comment:**

None

**Commissioners Response to Public Comments:**

None

*The following was taken out of order:*

**10. Report of Special Committees**

- Noise Report (July, October, January, April)
  - Christina Lounsbury reviewed the quarterly report of July, August, and September 2021. There were a total of 44 complaints made by 21 complainants. She reviewed the areas from which the complaints were originating.



- o Ms. Lounsbury noted that calls increased and most were about flights during the voluntary quiet hours. We are a public use airport and we are open 24/7 so these are voluntary guidelines.
- o Military do use the airport for training practices, this was discussed.
- o Ms. Lounsbury commented that one complainant has the perspective that flights during the quiet hours are a violation and requested extensive information. Her response to provide all of the information assisted with educating the individual that these are voluntary quiet hours and by law the Airport cannot close its facility to flights during these hours.

*Ms. Lounsbury left the meeting at 4:13 pm.*

**Finance Subcommittee (Commissioners Weill, Flores, and Bailey)**

The Finance Subcommittee met on Tuesday, October 5, 2021. Commissioner Weill read a review of the meeting (attached).

**Infrastructure & Marketing Subcommittee (Commissioners Young, and Bierwirth)** The Infrastructure & Marketing subcommittee met on Wednesday, October 5, 2021. Commissioner Young read a review of the meeting (attached).

**Old Business:**

**COM0921-04 - Approval of the FY2022 Business Plan Goals and Objectives**

**MOTION** to approve the Fiscal Year 2022 Business Plan Goals and Objectives to include measurable elements for each task and modifications as suggested by the Airport Commission.

**SPONSOR:** Infrastructure & Marketing Subcommittee (**May be acted upon**)

- This agenda item was moved and read by Chairman Griffin and seconded by Commissioner Flores. Management made modifications to the plan as suggested which included prioritizing the FY2022 initiatives into sound and realistically achievable goals that can be accomplished within the FY2022 window. Measurable elements were added to each one and updates will be provided to the Commission monthly.
- There are 110 tasks that the airport wishes to address in the FY2022 window. They span all four goals of the business plan.
- Manager Servis reviewed the power point outlining the status of each task as of October 18, 2021 (attached).
  - Behind Schedule (4 tasks):
    - o Objective: Identify and Create Corporate Aviation Opportunities
      - 3 Tasks: Three step process to evaluate what other airports have done to attract business.
    - o Objective: Engage Airlines to Develop Partnerships for the Cape and Island Market (Coordinate with airlines)
      - 1 Task: Research airports of similar size with air carrier activity
  - Not Yet Started (41 tasks):
    - o Goal A: Maximize General Aviation Activity at HYA
      - 17 Tasks Not Started = the vast majority incorporate corporate marketing, fuel distribution, outreach and GA events (we actually started)
    - o Goal B: Diversify Revenue Streams
      - 5 Tasks Not Started = land use development and RFP
    - o Goal C: Regional Air Transportation Leader
      - 10 Tasks Not Started = upcoming airport conferences
    - o Goal D: Enhance Airport Image & Branding
      - 9 Tasks Not Started = marketing for various events that have not yet
  - The top nine priorities for Fiscal Year 2022 were outlined:
    1. Municipal FBO Redevelopment (Goal A)



2. Mary Dunn Way Extension (Goal A & B)
  3. Land Use: Aviation Use - Hangar Development (Goal A & B)
  4. Land Use: Non-Aviation Use (Goal B)
  5. Engage Corporate Users (Goal A & B)
  6. Engage GA Aircraft Users (Goal A & B)
  7. Aviation Education (Goal A)
  8. Airport Marketing - Various Events/News (Goal A and D)
  9. Future FBO Positioning & Development (Goal A & B)
- Management would also like to host a future workshop with the Commission to discuss the next tier of priorities and the overall plan in advance of FY2023 development. The Airport has a unique opportunity here where some of the priorities may move up as we consider the use of CARES funding to meet long-term goals or unique opportunities.
  - Manager Servis reviewed the key details for each of the top priorities and the next steps for the Business Plan.
- Claudine LeBlanc, Creating Marketing Results, will be joining the November meeting to present event and sponsorship possibilities.
  - There was a discussion of Airline Conferences and the structure of attracting new service.
  - A focus on increased daily flights, usability of the airport, and the ability to fill the seats of new airlines was discussed; as well as marketing to non-airline entities. For the 600 daily travelers utilizing bus services, the airport is not currently a viable alternative. The service does not compare to Boston and Providence. The length of the runways does not accommodate many airline fleets. JetBlue is changing their fleet to larger aircraft. A future workshop will be scheduled to discuss marketing focuses.
  - This agenda item was unanimously approved by verbal vote:
 

|         |     |        |     |          |     |           |     |
|---------|-----|--------|-----|----------|-----|-----------|-----|
| Griffin | yes | Young  | yes | Weill    | yes | Bierwirth | yes |
| Flores  | yes | Bailey | yes | DiGeorge | yes |           |     |

**New Business:**

**COM1021-1 Approval of the Non-Federal Reimbursable Agreement by and Between the Department of Transportation Federal Aviation Administration and Cape Cod Gateway Commission**

**MOTION** to approve the 5 year Non-Federal Reimbursable Agreement by and between the Cape Cod Gateway Airport and the Department of Transportation Federal Aviation Administration to operate and maintain the communications systems in the Air Traffic Control Tower for fiscal years 2022 through 2026. **SPONSOR:** Finance Subcommittee **(May be acted upon)**

- This agenda item was moved and read by Chairman Griffin and seconded by Commissioner Weill.
- When the HYA Air Traffic Control Tower was constructed, it was done so at 100% federal funding. However, the building itself is under control of the airport and that includes all maintenance and repair.
- As part of the overall arrangement, an agreement exists between the FAA and the Airport to operate and maintain the communications systems for the facility. This Agreement provides funding for the FAA to establish these services. The Agreement is titled: Reimbursable, (HYA) Provide Maintenance for the Hyannis Communications Equipment for FY22- FY26 at Cape Cod Gateway Airport.
- The FAA will perform required monthly, quarterly, semi-annual and annual maintenance, flight inspection and documentation as necessary for various communications equipment outlined in the agreement such as radios, transmitters, headsets, microphones, etc.
- This control tower is contracted out to a non-federal agency to man the tower.



- The agreement identifies labor hours based on estimation for monthly, quarterly, semi-annual and annual maintenance, flight inspection and documentation.
- The cost estimates contained in the Agreement are expected to be the maximum costs associated with this Agreement, but may be amended to recover the FAA's actual costs. If during the course of this Agreement actual costs are expected to exceed the estimated costs, the FAA will notify the Airport and an amendment to the Agreement will be executed.
- This agreement does not include the cost of replacement for any of these systems. This is strictly a maintenance agreement. Replacement of any of the communications systems would be at an additional cost, in which the airport sets aside funding annually (\$10,000) for such replacement if needed
- The cost of the Agreement is as follows:
  - FY22 = \$13,665.00
  - FY23 = \$13,873.50
  - FY24 = \$14,092.43
  - FY25 = \$14,300.93
  - FY26 = \$14,530.28
  - Total FY22-26 = \$70,462.14
- The Airport typically prepays the entire estimated cost of the Agreement prior to the start of each fiscal year.
  - The advance payment will be held as a non-interest bearing deposit.
- This agenda item was unanimously approved by verbal vote:
 

|         |     |        |     |          |     |           |     |
|---------|-----|--------|-----|----------|-----|-----------|-----|
| Griffin | yes | Young  | yes | Weill    | yes | Bierwirth | yes |
| Flores  | yes | Bailey | yes | DiGeorge | yes |           |     |

**COM1021-2 Approval of the Cape Cod Gateway Airport Jet Fuel Discount Program**  
**MOTION** to approve the revised Cape Cod Gateway Airport Jet Fuel Discount Program effective October 19, 2021. **SPONSOR:** Finance Subcommittee **(May be acted upon)**

- This agenda item was moved and read by Chairman Griffin and seconded by Commissioner DiGeorge.
- The Airport Jet Fuel Discount Program has been in existence since 2012 and changes have been made to the program over the years to incorporate additional features, to modify tier levels and to ensure that the airport offered a fair and reasonable discount to entice participation.
- Modifications were made in 2015, 2017, 2020 and now in 2021
- The 2020 version reduced the number of tiers, with tier 1 starting at 100,001 gallons due to lack of participation below that mark.
- Currently Netjets and Everest are the two largest participators in our program with Everest well surpassing Netjets
- The programs were designed to include an annual contract with a fuel quota (Gold Program), an annual contract without the fuel quota (Silver Program) plus an annual contract without the fuel quota - loyalty program (Bronze Program)
- The discounts were modified with the Gold Program receiving the greatest discount (more risk for Fuel Purchaser) and Silver and Bronze still receiving a discount but at a lesser rate than the Gold.
- In the previous program the Airport identified the **cost per gallon Margin** that the Fuel Purchasers would pay under a discount program. In this version the Airport eliminated that and only identifies the cost savings per gallon (\$0.60 or \$0.30/gallon savings versus the Margin they would pay).
  - This approach still allows for a significant discount for the Fuel Purchaser but gives us flexibility to adjust our Margin with demand, season, and etc.
- This agenda item was unanimously approved by verbal vote:
 

|         |     |       |     |       |     |           |     |
|---------|-----|-------|-----|-------|-----|-----------|-----|
| Griffin | yes | Young | yes | Weill | yes | Bierwirth | yes |
|---------|-----|-------|-----|-------|-----|-----------|-----|



Flores        yes    Bailey        yes    DiGeorge        yes

**COM1021-3 Approval of the Jet Fuel Pricing Agreement by and Between the Cape Cod Gateway Airport and Everest Fuel Management, LLC**

**MOTION** to approve the one-year Jet Fuel Pricing Agreement by and between Cape Cod Gateway Airport and Everest Fuel Management, LLC effective October 19, 2021. **SPONSOR:** Finance Subcommittee **(May be acted upon)**

- This agenda item was moved and read by Chairman Griffin and seconded by Commissioner Bailey.
- Everest Fuel Management has contracted with the Airport since 2017.
- Their initial contract in 2017 started at 50,001 gallons of jet fuel (the "Fuel Quota")
- In 2018 they increased that to 100,001 gallons of jet fuel (the "Fuel Quota")
- In 2019/2020, they raised their purchase to 200,001 gallons of jet fuel (the "Fuel Quota")
- Each year they surpassed their Fuel Quota.
- In 2021 they raised their purchase to 400,001 gallons of jet fuel (the "Fuel Quota"). They actually purchased 567,327 gallons of jet fuel.
- This year they wanted to maintain the 400,001 gallon minimum purchase tier.
- This agenda item was unanimously approved by verbal vote:

|         |     |        |     |          |     |           |     |
|---------|-----|--------|-----|----------|-----|-----------|-----|
| Griffin | yes | Young  | yes | Weill    | yes | Bierwirth | yes |
| Flores  | yes | Bailey | yes | DiGeorge | yes |           |     |

**COM1021-4 Approval of the License Agreement by and Between the Cape Cod Gateway Airport and Heritage Turbines**

**MOTION** to approve the one-year \$1,500.00 Aviation Related Off-Airport Access and Land Use License Agreement by and between Cape Cod Gateway Airport and Heritage Turbines, Inc. Effective November 1, 2021. **SPONSOR:** Finance Subcommittee **(May be acted upon)**

- This agenda item was moved and read by Chairman Griffin and seconded by Commissioner Weill.
- This is the third year that the airport has held a License Agreement with Heritage Turbines for the right to access Airport property for the purposes of loading and offloading equipment.
- The loading dock abuts Airport property within an existing parking lot located behind the Heritage Turbine facilities.
- The Airport currently charges \$1500/access agreement.
- Management will be looking to increase such fees with the FY2022 Airport Rates and Charges modifications. This was also discussed with the Finance Subcommittee.
- This agenda item was unanimously approved by verbal vote:

|         |     |        |     |          |     |           |     |
|---------|-----|--------|-----|----------|-----|-----------|-----|
| Griffin | yes | Young  | yes | Weill    | yes | Bierwirth | yes |
| Flores  | yes | Bailey | yes | DiGeorge | yes |           |     |

**COM1021-5 Approval of the License Agreement by and Between the Cape Cod Gateway Airport and New England Aircraft Detailing**

**MOTION** to approve the one-year \$1,500.00 Aviation Related Off-Airport Access and Land Use License Agreement by and between Cape Cod Gateway Airport and New England Aircraft Detailing effective November 1, 2021. **SPONSOR:** Finance Subcommittee **(May be acted upon)**

- This agenda item was moved and read by Chairman Griffin and seconded by Commissioner Weill.



- This is the third year that the airport has held a License Agreement with New England Aircraft Detailing for the right to access Airport property for the purposes of washing aircraft.
- New England Aircraft Detailing enters the airport property to dry wash aircraft for various tenants.
- The Airport currently charges \$1500/access agreement.
- Management will be looking to increase such fees with the FY2022 Airport Rates and Charges modifications. This was also discussed with the Finance Subcommittee.
- Commissioner Bierwirth suggested marketing this firm to transient aircraft to have interiors cleaned. She would like to discuss at a future meeting.
- This agenda item was unanimously approved by verbal vote:
 

|         |     |        |     |          |     |           |     |
|---------|-----|--------|-----|----------|-----|-----------|-----|
| Griffin | yes | Young  | yes | Weill    | yes | Bierwirth | yes |
| Flores  | yes | Bailey | yes | DiGeorge | yes |           |     |

**COM1021-6 Review and Discuss the Capital Improvement Plan (CIP) for FY2023-FY2027 for Cape Cod Gateway Airport**

**MOTION** to approve the 5 year projected Capital Improvement Plan (CIP) for the FY2023-FY2027 for the Cape Cod Gateway Airport. **SPONSOR:** Finance Subcommittee **(May be acted upon)**

- This agenda item was moved and read by Chairman Griffin and seconded by Commissioner Weill.
- As discussed in the August meetings, a draft CIP was provided to the Finance Subcommittee and the Commission in anticipation of the future meeting with the State and Federal agencies to make sure that the Commission was on the same page as Airport Management regarding various future projects.
- Airport Management met with the State and Federal agencies on Monday September 27<sup>th</sup>.
- The projects listed in the various years FY2023-FY2027 remained as is in the DRAFT CIP with no further changes made in the year in which the projects are planned for implementation.
- The only modifications made were to update some of the cost estimates.
- The runway extension, which is part of the Airport Master Plan, is in the CIP to be implemented in 2027 after FAA required taxiway changes are completed.
- The Town of Barnstable Finance Department has received this CIP and it will be presented to the Town Council in November.
- This agenda item was unanimously approved by verbal vote:
 

|         |     |        |     |          |     |           |     |
|---------|-----|--------|-----|----------|-----|-----------|-----|
| Griffin | yes | Young  | yes | Weill    | yes | Bierwirth | yes |
| Flores  | yes | Bailey | yes | DiGeorge | yes |           |     |

**COM1021-7 Review and Discuss Federal Airport Grants & Status**

**MOTION** to approve the Federal Airport Grants and the use of the CARES Act grant to fund the remodel of the Fixed Base Operation and renovations to the building. **SPONSOR:** Management **(May be acted upon)**

- This agenda item was moved and read by Chairman Griffin and seconded by Commissioner Weill.
- There are three existing projects under the CARES Act Grant that have been approved by the Commission to move forward. These are the T-Hangar project, Replacement of the Fleet Hangar Doors, and the extension of Mary Dunn Way.
- The fourth project, remodel of the Airport's Fixed Based Operation and renovations, was requested to be funded with CARES Act funds by the Commission.
- The Marketing and Infrastructure Subcommittee asked that this project be of the highest priority and implemented ASAP using CARES Act funds. With the events that



are scheduled for FY2022, and response to pilot's needs, the building's interior space needs a facelift and safety protocols implemented to place the door in the appropriate location.

- Initially the Marketing and Infrastructure Subcommittee wanted a quick fix; new floors, paint, furniture, etc. Management consulted with Fennick McCredie Architecture to see if this was possible.
- Cost estimates for renovation were \$180,000 but this included a \$100,000 door, new entrance and vestibule. It did not include restroom renovations.
- In speaking to Fennick McCredie Architecture about the remodeling effort they indicated that the "quick fix" versus "full implementation" as originally planned with the new door would not be viable.

Based on accessibility law, the pilot space cannot be modified without upgrading and updating the restrooms to meet accessibility requirements/code due to regulations that require review of several factors when determining if the requirement to meet various building codes.

- This agenda item was unanimously approved by verbal vote:

|         |     |        |     |          |     |           |     |
|---------|-----|--------|-----|----------|-----|-----------|-----|
| Griffin | yes | Young  | yes | Weill    | yes | Bierwirth | yes |
| Flores  | yes | Bailey | yes | DiGeorge | yes |           |     |

**COM1021-8 Approval of the Amendment #9 by and Between Cape Cod Gateway Airport and Fennick McCredie Architecture in the Amount of \$66,356.00**

**MOTION** to approve the Amendment #9 to the Contract by and between the Cape Cod Gateway Airport and Fennick McCredie Architecture in the amount of \$66,356.00 for the T-hangar Replacement Project additional services. **SPONSOR:** Finance Subcommittee **(May be acted upon)**

- This agenda item was moved and read by Chairman Griffin and seconded by Commissioner Weill.
- In review of the T-Hangar replacement project, the pavement around the T-Hangar area needs to be replaced. It makes sense to so this at the same time as replacement of the building.
- This is for additional architectural services to complete pavement upgrades as part of the t-Hangar replacement project.
- This cost will be funded by the CARES Act Grant.
- This agenda item was unanimously approved by verbal vote:

|         |     |        |     |          |     |           |     |
|---------|-----|--------|-----|----------|-----|-----------|-----|
| Griffin | yes | Young  | yes | Weill    | yes | Bierwirth | yes |
| Flores  | yes | Bailey | yes | DiGeorge | yes |           |     |

**COM1021-9 Approval of the Ross Aviation Electric Vehicle Charging Station Development and Site Host Agreement**

**MOTION** to approve the Electric Vehicle Make Ready Program Site License Agreement by and between Cape Cod Gateway Airport and NSTAR Electric Company d/b/a Eversource Energy effective October 19, 2021 for the Ross Aviation Electric Vehicle Charging Station Development.

**SPONSOR:** Finance Subcommittee **(May be acted upon)**

- This agenda item was moved and read by Chairman Griffin and seconded by Commissioner DiGeorge.
- NSTAR provided a modified Site Host agreement to better align with the airport's needs and so that development and installation of the EV stations can proceed forward.
- Modifications were suggested by Airport Management within the agreement and accepted by NSTAR.
- Approval of the Site Host Agreement will allow Ross Aviation to proceed forward to development. The Airport will coordinate with both entities during the construction process and will require liability insurance from NSTAR.



- This agenda item was unanimously approved by verbal vote:
 

|         |     |        |     |          |     |           |     |
|---------|-----|--------|-----|----------|-----|-----------|-----|
| Griffin | yes | Young  | yes | Weill    | yes | Bierwirth | yes |
| Flores  | yes | Bailey | yes | DiGeorge | yes |           |     |

**COM1021-10 Approval of Ross Aviation Sign Plan**

**MOTION** to approve the Ross Aviation Sign Plan as presented. **SPONSOR:** Infrastructure & Marketing Subcommittee (**May be acted upon**)

- This agenda item was moved and read by Chairman Griffin and seconded by Commissioner DiGeorge.
- On August 18, 2021, Taryn Wilson of Sign Dealz reached out to the Airport regarding Signage Submittals for Ross Aviation located at 730 Barnstable Rd., Hyannis, MA 02601.
- Ross Aviation is in the process of modifying all Rectrix signage to matched the revised company name, logo and branding for Ross Aviation.
- There are five (5) signs total that need to be upgraded.
  - Of the five (5) signs...
    - One (1) is LED illuminated and mostly acrylic (this is the one on the secure side of the building facing the ramp)
    - All other signs are aluminum with 3M vinyl lettering and/or graphics
- They were asked to provide the following in order to make this leasehold improvement:
  - Detailed construction plans/engineering drawings for each sign must be submitted to Airport Management electronically.
  - Obtain all permits from local sources such as electrical work for the lighted sign - to be issued by the Town of Barnstable.
  - Liability Insurance listing the Airport additionally insured prior to construction
- Sign Dealz provided the following:
  - Signage Drawings along with Engineering for Ross Aviation Signage (HYA) at the Cape Cod Gateway Airport.
- The sign at the Mary Dunn Way entrance will be removed as part of the Sign Plan.
- This agenda item was unanimously approved by verbal vote:
 

|         |     |        |     |          |     |           |     |
|---------|-----|--------|-----|----------|-----|-----------|-----|
| Griffin | yes | Young  | yes | Weill    | yes | Bierwirth | yes |
| Flores  | yes | Bailey | yes | DiGeorge | yes |           |     |

**COM1021-11 Approval of the Sign Plan Modifications for Airport Access Road to Meet Rebranding Efforts**

**MOTION** to approve the Cape Cod Gateway Airport Sign Plan Modifications for the Airport Access Road to meet the rebranding efforts. **SPONSOR:** Infrastructure & Marketing Subcommittee (**May be acted upon**)

- This agenda item was moved and read by Chairman Griffin and seconded by Commissioner DiGeorge.
- The airport has been working to obtain quotes to replace the following:
  - Terminal building sign,
  - Wooden airport signs,
  - Existing airport access road signs, and
  - Highway signs.
- For FY2022, we have set aside \$50,000 for this task assuming that this will be Phase I of the plan.
- Terminal Sign Replacement
  - The terminal sign will be replaced with our new logo, font and colors for less than \$7,000 as the lowest quote from Plymouth Sign Company. Management would like approval to move forward to get this replaced as soon as possible.
- Existing airport access road signs





- o We have 27 blue airport access road signs in which we will investigate which needs to be modified.
- o We intend on reskinning these signs and maintaining the current locations.
- o There may be a few signs in which we relocate.
- o We will also investigate lighting some of the signs with solar lighting as many have commented on their difficulty to see at night.
- o Staff will work with the Procurement Office to obtain quotes.
- The Wooden signs
  - o We have two wooden signs, one at Attucks Lane and one at the Airport Rotary. In 2011 each sign cost ~\$8,000 to create so with inflation, these signs could cost somewhere in the realm of \$15,000 per sign.
  - o We would like to maintain wooden signs and will need to work with a sign maker to redesign each.
- Highway signs.
  - o We have 22 green and white MaSSDOT Highway signs, of those only 4-5 need to include the new name on the sign
  - o McFarland Johnson is working on correcting these with Mass DOT Aeronautics
- Commissioners made suggestions for the wooden signs and would like to see some other renderings and relocation of the rotary sign to a better visual area.
- The name change for the airport has received positive feedback from pilots, and mixed reviews from the community as they associate with, and wanted Barnstable still, but they understood that the Airport services all of Cape Cod.
- The GOOGLE name change is being worked on, but the verification process is lengthy. All of the FAA documentation has been modified. The airport identifier is still HYA.
- This agenda item was unanimously approved by verbal vote:
 

|         |     |        |     |          |     |           |     |
|---------|-----|--------|-----|----------|-----|-----------|-----|
| Griffin | yes | Young  | yes | Weill    | yes | Bierwirth | yes |
| Flores  | yes | Bailey | yes | DiGeorge | yes |           |     |

**Updates:**

- o A&P School
  - o Manager Servis has been communicating with the National Aviation Academy for several months and hopes to host Russ Cephas (Vice President of Operations) and Holli K. Hudson (Chief Strategy Officer (CSO) & Senior Executive Vice President) on an airfield tour. They seem eager to establish a satellite school at the Cape Cod Gateway Airport.
  - o In the past, conversations with the Cape Cod Community College (CCCC), they have not expressed a desire to establish a satellite school at HYA. Manager Servis attended a breakfast and tour of the Plymouth facility and learned that the program has greatly expanded to the point that they are now offering night courses. They went from 25 students/semester to the ability to accommodate 50 and still have enrollees on a wait list for fall and spring semesters.
  - o In speaking with the new CCCC Director of the AMT Program, Michael Sasso, they now have a desire and the ability to develop a satellite school. They would like to see the possibility of a dual enrollment course at Barnstable HS and/or other schools on the cape with a facility at HYA in the future
  - o Management would like to host a future Business Plan workshop with the Commission to discuss the next tier of priorities.
  - o This is a very unique opportunity where some of the Business Plan priorities may move up as we consider the use of CARES funding to meet long-term goals/unique opportunities.
  - o The Commission is in full support of moving forward to bring this to fruition.
- o Upcoming November Finance Items:



- o Hyannis Hangar LLC
  - o Griffin Avionics DRAFT Lease
  - o Modified/Updated Airport Rates & Charges
- o Upcoming November Infrastructure Items:
  - o Signage (Airport Access Road & Terminal)
  - o Sign design review
  - o FBO Renovation Discussion
  - o Business Plan Update – November 2021
  - o Website
- o Airport Finances Update
  - o Management to review with Finance Sub-committee and at the full Commission meeting
- o Airport Master Plan Update
  - o Complete - Final documentation going to FAA for review
- o Town of Barnstable Budget
  - o FY2023 Capital Improvement Plan meetings completed and will be submitted to the Town Council
  - o FY2023 Operating Budget to commence October 2021
- o Airport Environmental Assessment
  - o Selection of Epsilon Associates
  - o December 2021/January 2022 start as long as we have an approved Airport Layout Plan from the FAA
    - The Airport originally anticipated a October start but we must wait for the FAA to complete the review and approval of the proposed projects and that will take 90-days
- o PFOS/Public Involvement Plan & Update
  - o Management met with DEP on October 1 to go over Audit findings.
  - o Continuing data collection and preparing for submittal of a revision of the Phase II report to DEP in October/November 2021
- o Airport Rates & Charges Update (2021 review post-COVID19)
  - o FY2022 Management will start reviewing next week to include the new jet fuel program and airport access fees
  - o This will be presented at a public hearing after approval by the Commission
- o Rebranding & Website Upgrade
  - o Website modifications – underway and an interactive test website will be available soon for review
- o Dates to remember:
  - o Good Morning Networking Breakfast with Cape Cod Chamber Membership – October 29 8:30 am in the Airport café
  - o Airport Commissioners will hopefully join
- o Lease Development Update
  - o RFP Development for non-aviation parcels

**Adjournment:**

Upon Motion duly made and seconded, the meeting was adjourned at 6:14 PM. The next meeting will be held on November 16, 2021.

NORMAN WEILL, CLERK



Documents attached:

Noise Reporting July/August/September 2021

Finance Sub-committee speaking notes

Infrastructure & Marketing Subcommittee speaking notes

Cape Cod Gateway Airport FY2022 Business Plan Update – October 12, 2021

Jet Fuel Discount Program Schedule

Capital Improvement Plan FY2023 – FY2027

T-Hangar Pavement Area - T-Hangar Project

Ross Aviation Sign Plan



480 Barnstable Rd, Hyannis, MA 02601 | [flyHYA.com](http://flyHYA.com) | 508.775.2020

KATIE RILEY SERVIS Airport Manager | MATTHEW T. ELIA Assistant Airport Manager





### NOISE REPORT JUL/AUG/SEP 2021

| MONTH        | TOWN        | COMPLAINTS | COMPLAINANTS |
|--------------|-------------|------------|--------------|
| <b>JUL</b>   | Centerville | 1          | 1            |
|              | Dennis      | 1          | 1            |
|              | Hyannis     | 2          | 1            |
|              | Yarmouth    | 5          | 2            |
| <b>AUG</b>   | Hyannis     | 1          | 1            |
|              | Yarmouth    | 9          | 2            |
|              | Hyannis     | 1          | 1            |
|              | Yarmouth    | 4          | 2            |
| <b>SEP</b>   | Centerville | 2          | 1            |
|              | Hyannis     | 1          | 1            |
|              | Yarmouth    | 18         | 8            |
| <b>TOTAL</b> |             | <b>44</b>  | <b>21</b>    |

*Total reflects complaints counted once*

### 2020 Quarterly Comparison

| QUARTER                       | COMPLAINTS | COMPLAINANTS* |
|-------------------------------|------------|---------------|
| 1 <sup>st</sup> (JAN/FEB/MAR) | 2          | 2             |
| 2 <sup>nd</sup> (APR/MAY/JUN) | 36         | 15            |
| 3 <sup>rd</sup> (JUL/AUG/SEP) | 24         | 12            |
| 4 <sup>th</sup> (OCT/NOV/DEC) | 21         | 11            |
| <b>TOTAL</b>                  | <b>83</b>  | <b>31**</b>   |

*\*Unique complainants during quarter*

*\*\* Complainants total per year end*

### Past Year/Past Quarter Comparison

|                     | YEAR | COMPLAINTS | COMPLAINANTS |
|---------------------|------|------------|--------------|
| <b>3rd Quarter</b>  | 2020 | 24         | 12           |
|                     | 2021 | 44         | 21           |
| <b>Year-to-date</b> | 2020 | 62         | 29           |
|                     | 2021 | 76         | 43           |



480 Barnstable Rd, Hyannis, MA 02601 | flyHYA.com | 508.775.2020

KATIE RILEY SERVIS Airport Manager | MATTHEW T. ELIA Assistant Airport Manager



### Noise Complaint Report – July 2021

| <b>Date</b> | <b>Time</b> | <b>Name</b>   | <b>Town</b> | <b>Disturbance/Response</b>   |
|-------------|-------------|---------------|-------------|---|
| 7/2/2021    | 15:05       | Janet McAree  | Hyannis     | Reporting jet so low over her home she could have touched the tail.<br>Responded via mail that this was a jetBlue ARR to Runway 06 at 150 feet over her area. She less than 0.5 miles from the end of the runway.   |
| 7/5/2021    | 16:10       | Bill Garreffo | Centerville | Reporting air traffic all day long, every 12-15 minutes, starting at 08:05 and wanted the altitude of the very low jet at 16:10.<br>Responded via mail that between the hours of 08:00-16:30, only four of the flight were from HYA, and the rest were overflights not arriving or departing from HYA. The 16:10 aircraft was an overflight as well.  |
| 7/15/2021   | 06:18       | Gail Cassidy  | Yarmouth    | Reporting an aircraft that was too low and she was very alarmed.<br>Responded via email that: I did research on this flight and it was a student pilot with an instructor that was not following the requested flight path. While pilots are allowed to actually pick their path and can fly over an unrestricted area, I am going to reach out to the instructor. They are a tenant on the field and we expect that our tenants will follow the flight paths published. The altitude was not too low for the area (over 500 ft).                                 |
| 7/19/2021   | 23:23       | Steve Budreau | Yarmouth    | Email received 9/28/21 regarding July, Aug & Sept complaints for aircraft during the voluntary quiet hours, this date at 23:23, 23:26, 23:43 & 00:09.<br>Requesting owner of aircraft, airport arriving from or departing to and the purpose for the flight.<br>Responded via email that the quiet hours are voluntary and a request, not a requirement. Management requested I respond that we do not track the purpose for the flight and the additional information request for the 43 flights listed is accessible through our public flight tracking portal. |
| 7/20/2021   | 19:44       | Marie Brooks  | Dennis      | Reporting increase in traffic over her area, all very low, and that the flight paths changed as she has been there over 40+ years.<br>Responded via phone that her area is in the path of IFR arrivals to Rwy 24 and let her know there hasn't been a flight path change and the air traffic is actually down. On this date from 1000-2150 hrs there were 16 flights over her area with an average altitude of 1,380 ft (not low altitude). On this date in 2019 during the same hours, her area had 26 flights with an average altitude of 1,360 ft (not low).   |

|           |       |               |          |  |
|-----------|-------|---------------|----------|--|
| 7/22/2021 | 05:26 | Steve Budreau | Yarmouth | Email received 9/28/21 regarding July, Aug & Sept complaints for aircraft during the voluntary quiet hours, this date at 05:26 and 05:49. Requesting owner of aircraft, airport arriving from or departing to and the purpose for the flight.  |
|           |       |               |          | See response above.  |
| 7/23/2021 | 05:41 | Steve Budreau | Yarmouth | Email received 9/28/21 regarding July, Aug & Sept complaints for aircraft during the voluntary quiet hours, this date at 05:41 and 05:48. Requesting owner of aircraft, airport arriving from or departing to and the purpose for the flight.  |
| 7/28/2021 | 10:00 | Janet McAree  | Hyannis  | Reporting jet so low over her home that it was too close for comfort and she again stated she could have touched the tail of the aircraft from her yard.<br><i>Responded via mail that this was an ARR to Runway 06 at 175 feet over her area. She less than 0.5 miles from the end of the runway.</i> |
| 7/30/2021 | 05:10 | Steve Budreau | Yarmouth | Email received 9/28/21 regarding July, Aug & Sept complaints for aircraft during the voluntary quiet hours, this date at 05:10. Requesting owner of aircraft, airport arriving from or departing to and the purpose for the flight.  |
|           |       |               |          | See response above.  |



### Noise Complaint Report – August 2021

| <b>Date</b> | <b>Time</b> | <b>Name</b>       | <b>Town</b> | <b>Disturbance/Response</b>   |
|-------------|-------------|-------------------|-------------|---|
| 8/1/2021    | 05:31       | Steve Budreau     | Yarmouth    | Email received 9/28/21 regarding July, Aug & Sept complaints for aircraft during the voluntary quiet hours, this date at 05:31 and 23:52. Requesting owner of aircraft, airport arriving from or departing to and the purpose for the flight.<br><i>Responded via email that the quiet hours are voluntary and a request, not a requirement. Management requested I respond that we do not track the purpose for the flight and the additional information request for the 43 flights listed is accessible through our public flight tracking portal.</i> |
| 8/6/2021    | 16:30       | Irene Chausse     | Yarmouth    | Reporting air traffic all day long, which is not normal, and she wanted to know why there was aircraft over her area.<br><i>Responded via phone that her area is in the flight path for IFR ARR to Rwy 24 and depending on the meteorological conditions, air traffic can increase.</i>   |
| 8/6/2021    | 23:53       | Steve Budreau     | Yarmouth    | Email received 9/28/21 regarding July, Aug & Sept complaints for aircraft during the voluntary quiet hours, this date at 23:53. Requesting owner of aircraft, airport arriving from or departing to and the purpose for the flight.<br><i>See response above.</i>   |
| 8/7/2021    | 00:37       | Steve Budreau     | Yarmouth    | Email received 9/28/21 regarding July, Aug & Sept complaints for aircraft during the voluntary quiet hours, this date at 00:57. Requesting owner of aircraft, airport arriving from or departing to and the purpose for the flight.<br><i>See response above.</i>   |
| 8/7/2021    | 00:17       | Steve Budreau     | Yarmouth    | Email received 9/28/21 regarding July, Aug & Sept complaints for aircraft during the voluntary quiet hours, this date at 00:17. Requesting owner of aircraft, airport arriving from or departing to and the purpose for the flight.<br><i>See response above.</i>   |
| 8/14/2021   | 23:00       | Steve Budreau     | Yarmouth    | Email received 9/28/21 regarding July, Aug & Sept complaints for aircraft during the voluntary quiet hours, this date after at 23:00. Requesting owner of aircraft, airport arriving from or departing to and the purpose for the flight.<br><i>See response above.</i>   |
| 8/16/2021   | 07:25       | Stephan Blenkhorn | Hyannis     | Reporting via phone that there were two low and off course aircraft over his area (he is a retired pilot/flight instructor).<br><i>Responded that the aircraft were out of the voluntary noise abatement</i>  |



|           |       |               |          |   |
|-----------|-------|---------------|----------|---|
| 8/20/2021 | 05:00 | Steve Budreau | Yarmouth | flight path but their altitude was not low - over 700 feet. Also reported that I would contact the tenant. AMA contacted and also noted this was out of the path, but first complaint in months so they are doing an excellent job.           |
|           |       |               |          | Email received 9/28/21 regarding July, Aug & Sept complaints for aircraft during the voluntary quiet hours, this date three before 06:00. Requesting owner of aircraft, airport arriving from or departing to and the purpose for the flight. |
|           |       |               |          | See response above.   |
| 8/21/2021 | 00:24 | Steve Budreau | Yarmouth | Email received 9/28/21 regarding July, Aug & Sept complaints for aircraft during the voluntary quiet hours, this date at 00:24. Requesting owner of aircraft, airport arriving from or departing to and the purpose for the flight.           |
|           |       |               |          | See response above.   |
| 8/30/2021 | 22:36 | Steve Budreau | Yarmouth | Email received 9/28/21 regarding July, Aug & Sept complaints for aircraft during the voluntary quiet hours, this date at 22:36. Requesting owner of aircraft, airport arriving from or departing to and the purpose for the flight.           |
|           |       |               |          | See response above.   |



### Noise Complaint Report – September 2021

| Date      | Time  | Name               | Town     | Disturbance/Response  |
|-----------|-------|--------------------|----------|---|
| 9/1/2021  | 10:20 | Sandra Kristiansen | Yarmouth | Reporting via phone that a very low plane flying out of the VNAFP, not over the bay and wanted to know why it was so dangerously low.<br>Responded via phone that the flight was actually flying IFR (correct path) and was at 350 ft in altitude. Caller stated that it was much lower and she knows what she saw and our report was incorrect.  |
| 9/3/2021  | 00:01 | Jane Russo         | Yarmouth | Reporting jets over her home after midnight and wanted to know why they were allowed to fly after hours.<br>Responded via email (per her request) that HYA's public use airport status and how aircraft arrive and depart her area.   |
| 9/3/2021  | 07:35 | Stephan Blenkhorn  | Hyannis  | Reporting via phone that again there were low and off course aircraft over his area (he is a retired pilot/flight instructor).<br>Responded that the aircraft were again out of the voluntary noise abatement flight path and AMA was requested to speak with the pilots and give a reminder of the VNAFP. AMA assured this would be addressed.   |
| 9/3/2021  | 23:00 | Steve Budreau      | Yarmouth | Email received 9/28/21 regarding July, Aug & Sept complaints for aircraft during the voluntary quiet hours, this date after 23:00. Requesting owner of aircraft, airport arriving from or departing to and the purpose for the flight.<br>Responded via email that the quiet hours are voluntary and a request, not a requirement. Management requested I respond that we do not track the purpose for the flight and the additional information request for the 43 flights listed is accessible through our public flight tracking portal. |
| 9/4/2021  | 22:57 | Steve Budreau      | Yarmouth | Email received 9/28/21 regarding July, Aug & Sept complaints for aircraft during the voluntary quiet hours, this date at 22:57, 23:27, 23:41. Requesting owner of aircraft, airport arriving from or departing to and the purpose for the flight.<br>See response above.  |
| 9/10/2021 | 15:36 | Christine Greeley  | Yarmouth | Reporting via phone: "I have been quite bothered for a number of weeks now because of the flights at 6:00 that are taking off over the house, I have also had flights taking place after 11:00 and there have also been helicopter flights which actually intrigues me. The actual specific reason I am calling today Friday, September 10th at 3:36 is a plane, a large one, flew from   |

|           |       |               |          |  |
|-----------|-------|---------------|----------|--|
|           |       |               |          | <p>Hyannis Harbor up Glenwood Street and literally made the left hand turn at 40 Glenwood Street. I don't understand this, and don't understand the need of why an airplane would come in over the residential neighborhood from the harbor as opposed to coming in over at Lewis Bay. So I would like some information about why this plane today flew that path and I am sorry I don't like the idea that the tower told them it was okay to do it. This is ridiculous; the tower should not be sending them up residential streets to then make a left hand turn. Thank you and I appreciate the response in writing.</p> <p><i>Responded via mail: Thank you for reaching out to the airport on Friday, September 10, 2021. I want to address all of the concerns you mention in the call. In your voicemail you mentioned that you've experienced aircraft operating in the 6:00 a.m. hour and after 11:00 p.m. As a public use airport the facility is in operation 24 hours a day. However, please know that the airport continues to promote the voluntary quiet hours from 10:00 p.m. to 6:00 a.m., but please keep in mind that this is completely voluntary. With helicopter traffic, the airport does frequently see arrivals and departures of helicopters (med flights, military operations and private flights) and I am not sure what your question is, but if you would like to elaborate further, I would be happy to address any concerns or provide additional information where possible. Finally, the arrival to Runway 33 that you specifically requested we review was an arrival from Boston. I reviewed the flight track with the Assistant Airport Manager Matthew Elia and we determined this flight was coming from the northwest and entered the traffic pattern to land on Runway 33. Many arrivals in your vicinity often come from the South and follow the path you normally see, but this aircraft was in the traffic pattern from a northerly direction. As a result, it would be expected that an aircraft coming from the northwest for a landing on Runway 33 would be making the turn in the vicinity of your area to arrive to this runway.</i></p> |
| 9/10/2021 | 22:56 | Steve Budreau | Yarmouth | <p>Email received 9/28/21 regarding July, Aug &amp; Sept complaints for aircraft during the voluntary quiet hours, this date at 22:56 and 23:57. Requesting owner of aircraft, airport arriving from or departing to and the purpose for the flight.</p> <p><i>See response above.</i></p>   |
| 9/11/2021 | 23:42 | Steve Budreau | Yarmouth | <p>Email received 9/28/21 regarding July, Aug &amp; Sept complaints for aircraft during the voluntary quiet hours, this date at 23:42. Requesting owner of aircraft, airport arriving from or departing to and the purpose for the flight.</p> <p><i>See response above.</i></p>   |
| 9/12/2021 | 22:57 | Steve Budreau | Yarmouth | <p>Email received 9/28/21 regarding July, Aug &amp; Sept complaints for aircraft</p>   |

|           |       |                   |             |  |
|-----------|-------|-------------------|-------------|--|
|           |       |                   |             | during the voluntary quiet hours, this date 22:57. Requesting owner of aircraft, airport arriving from or departing to and the purpose for the flight.<br>See response above.  |
| 9/13/2021 | 23:44 | Steve Budreau     | Yarmouth    | Email received 9/28/21 regarding July, Aug & Sept complaints for aircraft during the voluntary quiet hours, this date at 23:44, 23:48, 23:58. Requesting owner of aircraft, airport arriving from or departing to and the purpose for the flight.<br>See response above.   |
| 9/14/2021 | 00:18 | Steve Budreau     | Yarmouth    | Email received 9/28/21 regarding July, Aug & Sept complaints for aircraft during the voluntary quiet hours, this date at 00:18 and 00:25. Requesting owner of aircraft, airport arriving from or departing to and the purpose for the flight.<br>See response above.   |
| 9/14/2021 | 23:00 | Deborah Fernandes | Yarmouth    | Reporting via phone that there was an extremely large and very low jet that departed over her and it was so low she was worried it would crash.<br><i>Reported via phone that this was a Gulfstream III that is older and louder, but was at 1,025 ft in altitude and not at all low or dangerous. We spoke about how a loud aircraft would seem louder at night without the ambient background noise does present louder. She said she was just glad the airplane didn't crash.</i> |
| 9/14/2021 | 23:00 | Jane Russo        | Yarmouth    | Reporting via phone a very large jet, that sounded like the US Airforce, that was after hours and this is unacceptable.<br><i>Report via phone (left message) explaining that this was a Gulfstream III departing, that the curfew hours are only voluntary and gave her the altitude (no return call).</i>  |
| 9/18/2021 | 23:20 | Steve Budreau     | Yarmouth    | Email received 9/28/21 regarding July, Aug & Sept complaints for aircraft during the voluntary quiet hours, this date at 23:20. Requesting owner of aircraft, airport arriving from or departing to and the purpose for the flight.<br>See response above.   |
| 9/19/2021 | 00:03 | Steve Budreau     | Yarmouth    | Email received 9/28/21 regarding July, Aug & Sept complaints for aircraft during the voluntary quiet hours, this date at 00:03 and 00:20. Requesting owner of aircraft, airport arriving from or departing to and the purpose for the flight.<br>See response above.   |
| 9/19/2021 | 07:58 | Bill Garreffi     | Centerville | Reported via phone that he wanted a written response for two aircraft at 07:58 and 21:07.<br><i>Responded via mail that at 07:58 aircraft was a departure to MVY and at 825 ft and at 21:07 was a departure to HPN (White Plains, NY) at 2,925 ft.</i>   |

|           |       |                     |             |   |
|-----------|-------|---------------------|-------------|---|
| 9/22/2021 | 16:15 | Bill Garreff        | Centerville | <p>Reported via phone disturbances at 06:13, 06:15, 06:18, 06:26, 06:28 and wanted the altitude for the extremely low and unsafe flights at 16:15 and 18:05.</p> <p>Responded via mail:<br/>I researched the altitudes for the two flights over your area and found the following information:</p> <ul style="list-style-type: none"> <li>• At 4:15 p.m. this was an arrival to Runway 15 at an altitude of 1100 feet and was not low in altitude nor a safety issue</li> <li>• 6:05 p.m., this was an arrival to Runway 15 at an altitude of 900 feet and was also not low in altitude nor a safety issue</li> </ul> <p>Regarding the other flights reported at 6:13, 6:15, 6:18, 6:26 and 6:28 p.m., only the 6:13 flight was a departure from our airport and the other four flights were overflights, neither arriving or departing from our airport.</p> <p>Email received 9/28/21 regarding July, Aug &amp; Sept complaints for aircraft during the voluntary quiet hours, this date at 11:28. Requesting owner of aircraft, airport arriving from or departing to and the purpose for the flight.</p> <p>See response above.</p> |
| 9/25/2021 | 23:28 | Steve Budreau       | Yarmouth    | <p>Email received 9/28/21 regarding July, Aug &amp; Sept complaints for aircraft during the voluntary quiet hours, this date four between 04:30-06:00. Requesting owner of aircraft, airport arriving from or departing to and the purpose for the flight.</p> <p>See response above and further note this was two Cape Air Pilots conducting their night currency – dark hours – that was not approved by the Chief Pilot, was in error and should not happen moving forward without notice and only one pilot at a time.</p>  |
| 9/27/2021 | 04:30 | Steve Budreau       | Yarmouth    | <p>Reporting early morning activity that was too early and woke him up. Caller expressed issue through Rep. Diggs office.</p>   |
| 9/27/2021 | 04:30 | Christopher Wyckoff | Yarmouth    | <p>Reported to caller via phone the cause of the early morning flights and Cape Air's response. He further reported that air traffic should not start before 06:00 and since he lives so close to the airport (Presidential Heights – West Yarmouth off Willow Street) and that the airport should pay for either sound proofing for his home or vegetation berms on the perimeter. He recently purchased his home and was not aware of the air traffic he would experience. I spoke with him attempting to explain the FAA regulations and past air traffic, but his only acceptable response would be curfews or sound mitigation.</p>  |



Speaking Notes: Infrastructure & Marketing 10-05-21

Met Tuesday, October 5, 2021 @ 10:33 am

Commissioners Young, Bierwirth, and DiGeorge were present. The meeting was held via ZOOM.

**UNFINISHED BUSINESS:**

**I0621-02 – Review and Discuss Ross Aviation Electric Vehicle Charging Station Development and Site Host Agreement.**

- NSTAR had approved the recent Site Host Agreement that was provided to them
- This will be on the agenda for approval at the October Commission meeting
- Ross Aviation stated that there will be 8 chargers installed (4 dual ports) in their parking lots for availability to their employees and customers
- It will take 6 to 8 weeks for the installation after the approval by the commission
- 

**I0721-03 – Review and Discuss in Detail FY2022 Business Plan Goals and Objectives**

- Management made modifications to the plan as suggested by the sub-committee which included prioritizing the FY2022 initiatives (prioritizing the priorities) into sound and realistically achievable goals that can be accomplished within the FY2022 window
- Manager Servis discussed each of the high priority tasks and gave an update on their progress.

**NEW BUSINESS:**

**IN1021-1 Review and Discuss Ross Aviation Sign Plan**

- Ross Aviation is in the process of modifying all Rectrix signage to match the revised company name, logo and branding
- Ross Aviation provided:
  - Detailed construction plans/engineering drawings for each sign
  - All Town of Barnstable permits
  - Liability Insurance listing the Airport additionally insured prior to construction
- Sign Dealz provided Signage Drawings and Engineering for Ross Aviation Signage

**IN1021-2 Review and Discuss the Sign Plan Modifications for Airport Access Road to Meet Rebranding Efforts**

- The Airport will be requesting quotes to replace the following: Terminal building sign, Wooden airport signs, Existing airport access road signs, and Highway signs.
- The Terminal sign will be replaced with our new logo, font and colors as soon as possible.
- Existing 27 airport access road signs will be reskinned and possibly lit for night visibility.
- The Wooden signs will be redesigned with the new logo and replaced prior to spring.
- Of the 22 green and white Highway signs, only 4 or 5 need to include the new name on the sign. These will be updated by MassDOT Aeronautics.
- 

**IN1021-3 Review and Discuss the Cape Cod Gateway Airport Fixed Based Operation (FBO) Remodel**

- In speaking to the architects, and based on accessibility law, the Airport cannot modify the pilot space without upgrading and updating the restrooms to meet accessibility requirements/code.
- Regulation requires that the following evaluation is used to analyze the building code requirements:
  - The building is assessed between \$1M - \$3M
  - Public spaces in building (entry & lobby, WC if provided for public) = 5% of building area.
  - Assessed value of public spaces = \$150k.
  - 30% of that is \$45k.
  - The recent roof upgrade (\$592,334.25) counts towards the % and analysis so the 30% Rule triggers full accessibility upgrades for public spaces.

**Updates:**

- Management gave a synopsis of the status of the PFAS mitigation at the Airport. The FAA is still investigating to find a replacement for the current specifications for the approved Fire Fighting foam by January 2023.
- Congratulations to Matt Elia and Katie Servis for a successful Mass Casualty Drill.

**Adjournment: Having no other business to discuss, the meeting was adjourned at 12:03 p.m.**





**Met Tuesday, October 5<sup>th</sup>, 2021**

The meeting was held via ZOOM.

Meeting was called to order at 8:31 a.m.

Commissioners Weill, Flores & Bailey was present via zoom.

Minutes of the August 3<sup>rd</sup>, 2021 Finance Subcommittee approved and will be signed at a later date.

**OLD BUSINESS;**

There was no old business to discuss.

**NEW BUSINESS**

***F1021-1 Review and Discuss the Non-Federal Reimbursable Agreement by and Between the Department of Transportation Federal Aviation Administration and Cape Cod Gateway Commission.***

- When the HYA Air Traffic Control Tower was constructed, it was done so at 100% federal funding.
- The building is under control of the airport and that includes all maintenance and repair.
- The Airport to operate and maintain the communications systems for the facility. This Agreement provides funding for the FAA to establish these services.
- This is strictly a maintenance agreement. Replacement of any of the communications systems would be at an additional cost, in which the airport sets aside funding annually (\$10,000) for such replacement if needed.
- The agenda item was moved to the October 19<sup>th</sup>, 2021 Full Commission meeting for approval.

***F1021-2 Review and Discuss the Cape Cod Gateway Airport Jet Fuel Discount Program***

- The Airport Jet Fuel Discount Program has been in existence since 2012 and changes have been made to the program over the years to incorporate additional features, to modify tier levels and to ensure that the airport offered a fair and reasonable discount to entice participation.
- The programs were designed to include an annual contract with a fuel quota and annual contract without the fuel quota.
- Manager Servis stated we are in alignment with other airports and the new fuel agreement we have the flexibility to increase our margin to be competitive to surrounding airports.
- The agenda item was moved to the October 19<sup>th</sup>, 2021 Full Commission meeting for approval.

***F1021-3 Review and Discuss the Jet Fuel Pricing Agreement by and Between the Cape Cod Gateway Airport and Everest Fuel Management, LLC.***

- Everest Fuel Management has contracted with the Airport since 2017 and each year they surpassed their Fuel Quota.
- In 2021 they raised their purchase to 400,001 gallons of jet fuel
- Manager Servis stated Everest has already agreed to sign agreement
- The agenda item was moved to the October 19<sup>th</sup>, 2021 Full Commission meeting for approval.

***F1021-4 Review and Discuss the License Agreement by and Between the Cape Cod Gateway Airport and Heritage Turbines.***

- This is the third year that the airport has held a License Agreement with Heritage Turbines for the right to access Airport property for the purposes of loading and unloading equipment
- The loading dock abuts Airport property within an existing parking lot located behind the Heritage Turbine facilities
- The Airport currently charges \$1500/access agreement
- The agenda item was moved to the October 19<sup>th</sup>, 2021 Full Commission meeting for approval.

***F1021-5 Review and Discuss the License Agreement by and Between the Cape Cod Gateway Airport and New England Aircraft Detailing***

- This is the third year that the airport has held a License Agreement with New England Aircraft Detailing for the right to access Airport property for the purposes of washing aircraft
- New England Aircraft Detailing enters the airport property to dry wash aircraft for various tenants
- The Airport currently charges \$1500/access agreement
- The agenda item was moved to the October 19<sup>th</sup>, 2021 Full Commission meeting for approval.

***F1021-6 Review and Discuss the Capital Improvement Plan (CIP) for FY2023-FY2027 for Cape Cod Gateway Airport***

- Manager Servis reviewed FY2023 –FY2027 CIP Presentation
- Airport Management met with the State and Federal agencies on Monday September 27, 2021.
- There are no changes in the year in which the projects are planned for implementation.
- The only modifications made were to update some of the cost estimates, and change to the Easements runway protection zone.
- The agenda item was moved to the October 19<sup>th</sup>, 2021 Full Commission meeting for approval.

***F1021-7 Review and Discuss Federal Airport Grants & Status.***

- Airport Management reviewed suggested modifications regarding the disposition of the Airport's Fixed Based Operation and renovations as suggested by the Marketing and Infrastructure Subcommittee.
- The agenda item was moved to the October 19<sup>th</sup>, 2021 Full Commission meeting for approval.

***F1021-8 Review and Discuss Amendment #9 by and Between Cape Cod Gateway Airport and Fennick & McCredie Architecture.***

- Airport Management reviewed suggested modifications regarding the additional task to complete pavement upgrades as part of the T-Hangar replacement project.
- Management has requested Fennick McCredie add this to their scope of work.
- The agenda item was moved to the October 19<sup>th</sup>, 2021 Full Commission meeting for approval.

**Updates:**

- Upcoming November Finance Items:
  - Hyannis Hangar LLC – Manager Servis has a meeting on Thursday 10/07/21 with them and this update will on November meeting.
- Airport Finances Update:
  - Manager Servis will send out later today (10/05/21).
- Dates to remember:
  - Good Morning Networking Breakfast with Cape Cod Chamber Membership – October 29<sup>th</sup> 0800 Airport Café.

**Additional Discussion:**

Commissioner Weill asked if anyone read the Newspaper Article featured yesterday on PFAS and how the article seemed to make the Airport the largest target. Manager Servis stated she thought the article shed light on the fact that it is beyond the Airport and Fire Academy and reflected a larger picture of contributors.

Meeting Adjourned: 9:51 a.m.

# Cape Cod Gateway Airport

FY2022 Business Plan Update  
Airport Commission Presentation

As of October 12, 2021

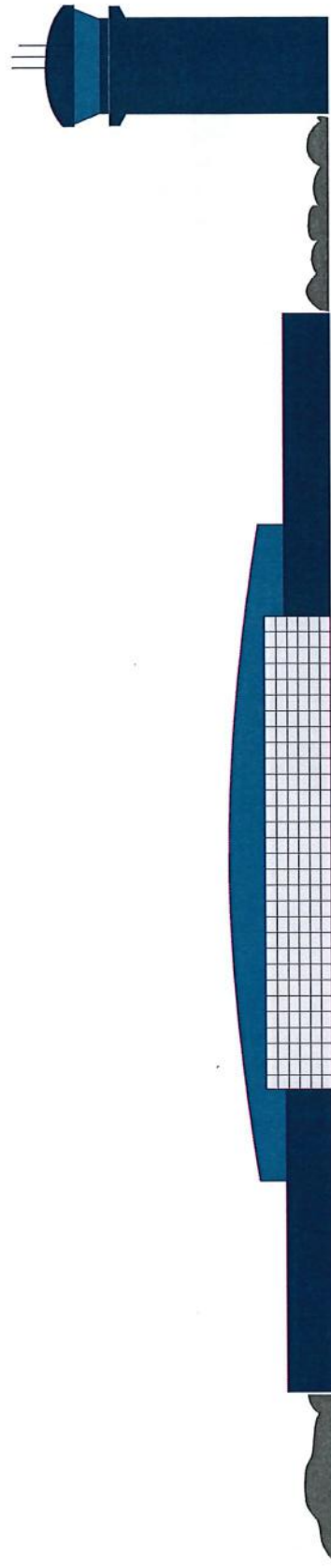

# FY2022 Business Plan Summary

% of Tasks Completed

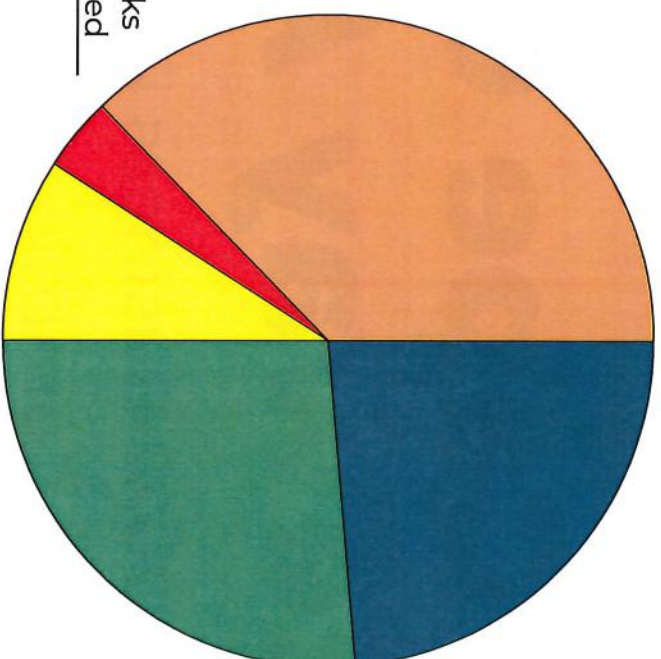

- Completed 26
- On Track 29
- Under Development 10
- Behind Schedule 4
- Not Yet Started 41

| Task Status           | # of Tasks | % of Tasks Completed |
|-----------------------|------------|----------------------|
| Completed             | 26         | 24%                  |
| On Track              | 29         | 26%                  |
| Under Development     | 10         | 9%                   |
| Behind Schedule       | 4          | 4%                   |
| Not Yet Started       | 41         | 37%                  |
| <b>Total Tasks FY</b> | <b>110</b> |                      |

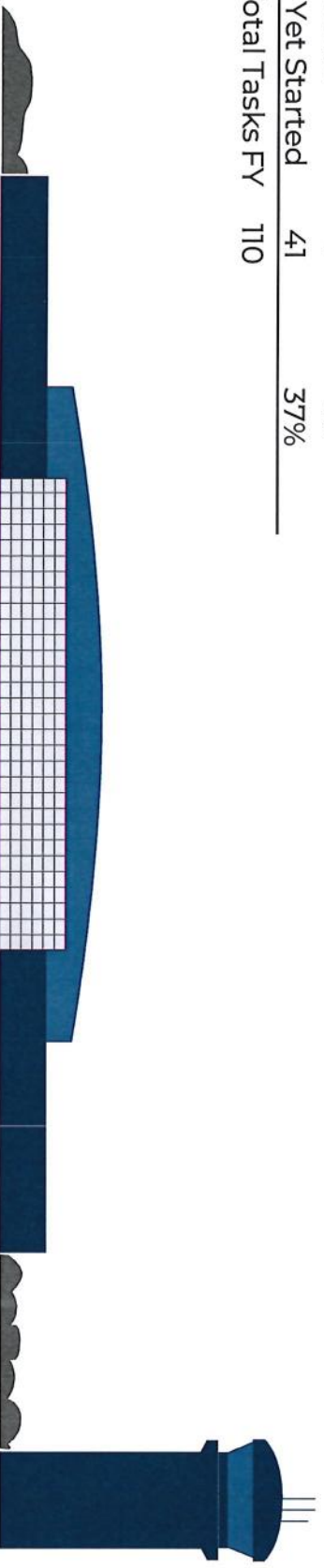

# Tasks Behind Schedule/Not Started

- Behind Schedule (4 tasks):
  - Objective: Identify and Create Corporate Aviation Opportunities
    - 3 Tasks: Three step process to evaluate what other airports have done to attract business.
      - We were suppose to start this 10/1/2021 but plan to get on this by 11/1/2021
  - Objective: Engage Airlines to Develop Partnerships for the Cape and Island Market
    - Coordinate with airlines
    - 1 Task: Research airports of similar size with air carrier activity
      - We were suppose to start this 10/1/2021 but plan to get on this by 11/1/2021 working with MJ

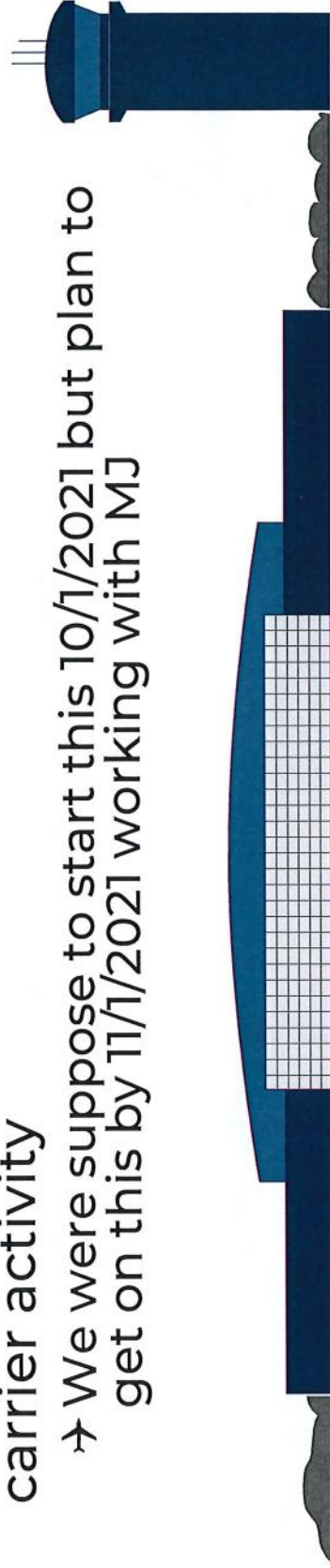

# Tasks Behind Schedule/Not Started (Cont.)

- Not Yet Started (41 tasks):
  - Goal A: Maximize General Aviation Activity at HYA
    - 17 Tasks Not Started = the vast majority incorporate corporate marketing, fuel, outreach and GA events
  - Goal B: Diversify Revenue Streams
    - 5 Tasks Not Started = land use development and RFP
  - Goal C: Regional Air Transportation Leader
    - 10 Tasks Not Started = upcoming airport conferences
  - Goal D: Enhance Airport Image & Branding
    - 9 Tasks Not Started = marketing for various events that have not yet started

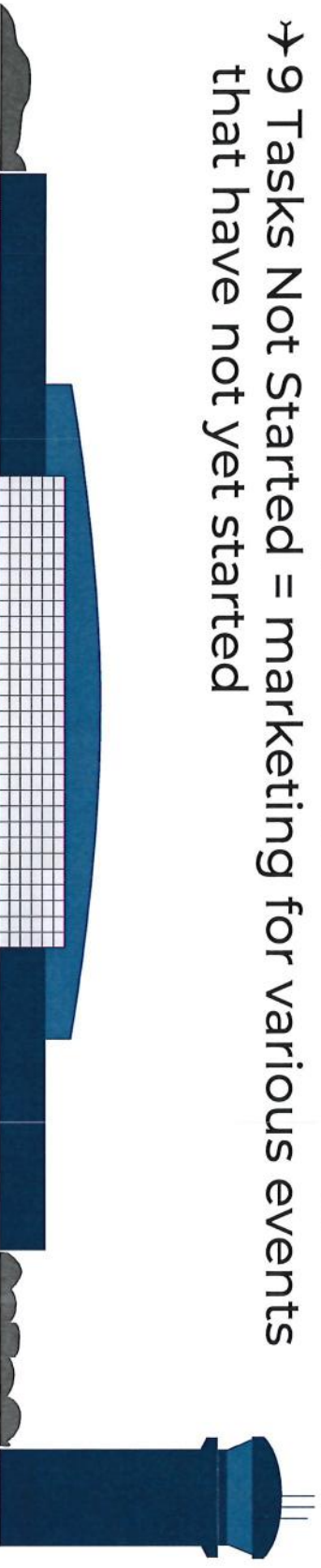

# FY2022 Top 9

| Top 9 Tasks Status                          | # of Tasks/Category | Task Status       |
|---|---------------------|-------------------|
| Municipal FBO Redevelopment                 | 1                   | On Track          |
| Mary Dunn Way Extension                     | 2                   | On Track          |
| Land Use: Aviation Use - Hangar Development | 2                   | On Track          |
| Land Use: Non-Aviation Use                  | 4                   | Under Development |
| Engage Corporate Users                      | 2                   | Under Development |
| Engage GA Aircraft Users                    | 5                   | Not Yet Started   |
| Aviation Education                          | 11                  | Not Yet Started   |
| Airport Marketing - Various Events/News     | 1                   | On Track          |
| Future FBO Positioning & Development        | 1                   | Not Yet Started   |
| Total Tasks For Top 9                       | 4                   | Not Yet Started   |
|   | 35                  |                   |

Task Status

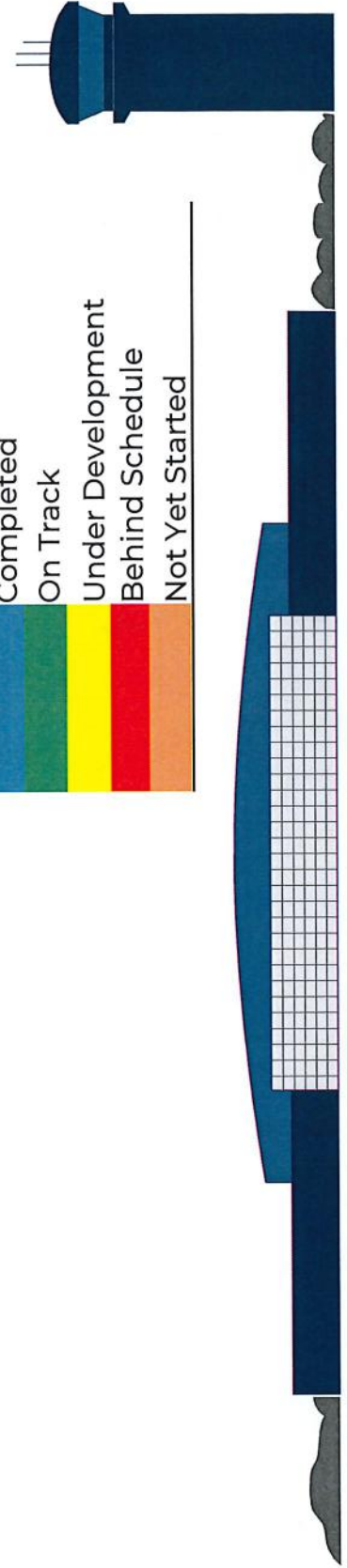
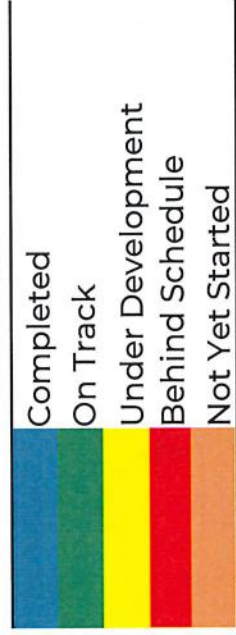

# FY2022 Business Plan

## Key Details – Top 9

- Municipal FBO Redevelopment
  - Project moving forward. As of the 10/5/2021 subcommittee meetings, the Finance subcommittee was onboard with using CARES Act Funds to develop the space.
  - On-call architects are developing the SOW as of 10/5/2021
- Mary Dunn Way Extension
  - Construction slated for Winter 2022. 90% design plans are completed
- Land Use: Aviation Use – Hangar Dev.
  - Project on track but is dependent on developers. We have made proposals to two entities wishing to develop hangars on property
  - Mary McDonald to contact waitlist to gain feedback by 10/15/2021

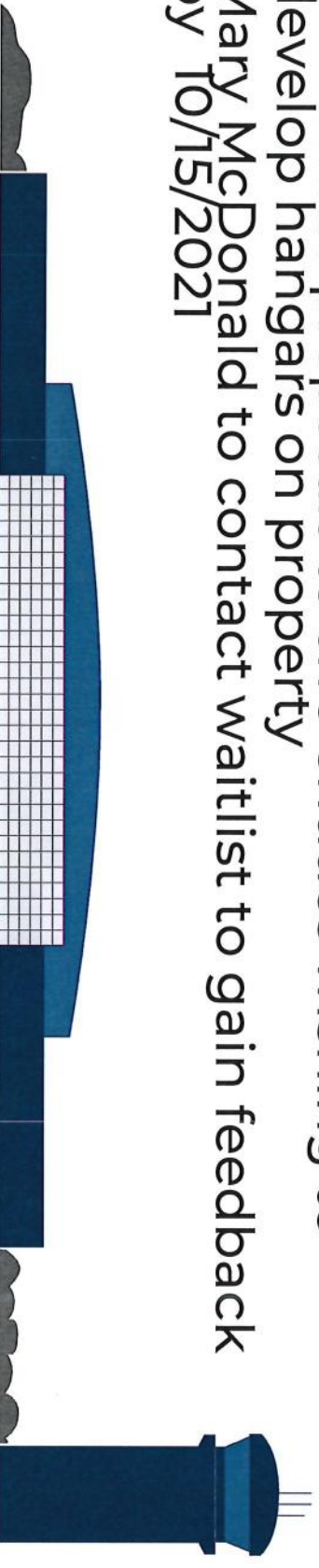
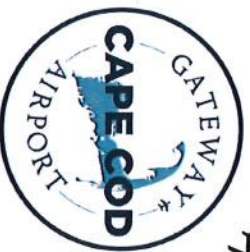



# FY2022 Business Plan Key Details – Top 9 (Cont.)

- Land Use: Non-Aviation Use
  - Develop of RFPs for 3 available vacant parcels (Mildred's, lot across the street from Cape Air, grass parking lot under agreement)
- Engage Corporate Users
  - Various tasks are either under development or not yet started (scheduled for December start)
- Engage GA Aircraft Users
  - Various tasks are either on track or not yet started (scheduled for December start to coincide with event planning)
- Aviation Education
  - Various tasks are not yet started (scheduled for December start to coincide with event planning)

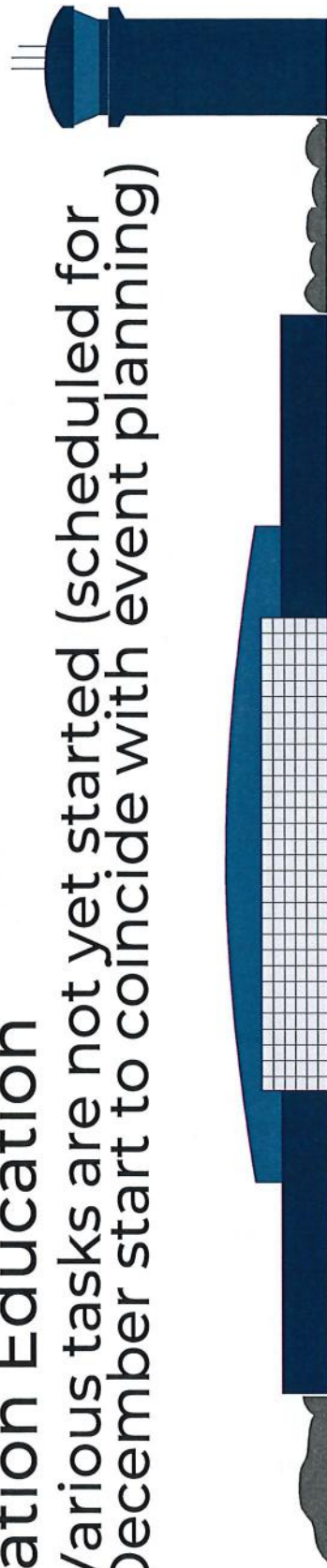

# FY2022 Business Plan Key Details – Top 9 (Cont.)

- Airport Marketing - Various Events/News
  - Various tasks are either on track or not yet started
  - Working with marketing team to outline various marketing efforts. Working with Claudine M. LeBlanc, President & Founder of Creating Marketing Results LLC (Plymouth) for local marketing. We started working with Claudine on 9/20/2021
- Outreach for MCI Drill completed
- Airport Terminal Sign Replacement – upcoming
- Environmental Assessment Kickoff – upcoming
- Various airport related events – upcoming
- Environmental stewardship – upcoming
- Future FBO Positioning & Development
  - Not yet started (May 2022 anticipated)



# FY2022 Business Plan

## Next Steps

- Concentrate on moving “Behind Schedule Tasks” to “Under Development”
- Update Commission on progress of Top 9 Tasks in November

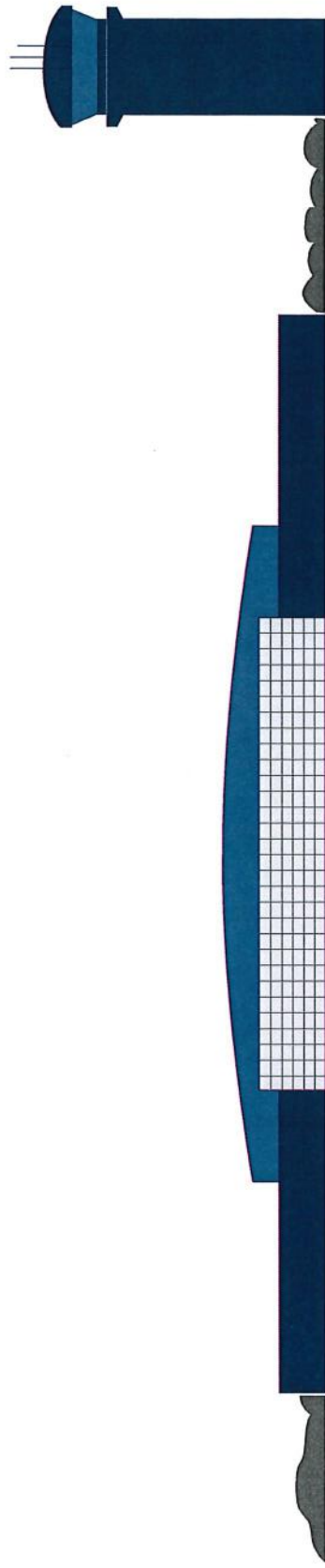





## CAPE COD GATEWAY AIRPORT JET FUEL DISCOUNT PROGRAM

Effective Date: October 19, 2021

---

Effective on the date above, the Cape Cod Gateway Airport Commission has revised the jet fuel discount program dated February 18, 2020 as outlined below and shown on the attached pricing schedules.

The regular retail price of jet fuel at Cape Cod Gateway Airport ("Fuel Seller") is based upon the PLATTS New York Harbor Jet Barge Mean Previous Week wholesale price, plus the cost differential and transportation costs billed by Fuel Seller's fuel supplier, plus applicable Federal taxes and Fuel Seller handling costs, to determine Fuel Seller's "cost of fuel." The Fuel Seller adds a margin per gallon to all fuel to arrive at a retail price, adjusted on a weekly basis. The margin is the amount between the selling price of fuel and the cost of fuel. The margin is calculated internally based on demand for fuel and the Fuel Seller's cost of doing business, which includes all fees associated with the Fueling Cost Center such as staff salaries, necessary staff training to meet federal fuel delivery safety standards, fuel truck leases and maintenance, fuel truck insurance, hazardous materials transport and pollution insurance, and other overhead associated with the Fueling Cost Center. This margin is adjusted on a weekly basis.

Discounts will be offered to those under contract to purchase jet fuel from the Fuel Seller. As shown in the pricing noted below, the "Discount Rate" will be provided to purchasers of jet fuel ("Fuel Purchaser") under contract ("Fuel Agreement").

Discounts will be offered to those under Fuel Agreement. The term of the Fuel Agreement is twelve (12) months from the date the Fuel Agreement is signed, the ("Effective Date") and will terminate on the twelve (12) month anniversary of the Effective Date.



---

480 Barnstable Rd, Hyannis, MA 02601 | [flyHYA.com](http://flyHYA.com) | 508.775.2020

KATIE RILEY SERVIS Airport Manager | MATTHEW T. ELIA Assistant Airport Manager

Discounts for Fuel Purchaser under a Fuel Agreement to purchase jet fuel from the Fuel Seller will be available to purchasers who own or operate an aircraft, or manage aircraft (or fleets of aircraft) under FAR Parts 91K, 121, and 135. Supporting documentation will be required.

In order to qualify for the various discount programs, participants must either:

- a. Utilize a 0% transaction charge credit card, such as the Philips card, or other Fuel Seller approved credit card; or
- b. Prepay the Fuel Seller sufficient funds to cover anticipated fuel purchases; or
- c. Prior agreed upon fuel purchases would be billed under a Net 10 payment plan.

See notes for each program below and Attachment A for credit and payment terms.

There are three (3) types of discounts now available under a contractual basis with the Fuel Seller. Fuel Purchasers must enter into Fuel Agreement with the Fuel Seller to qualify.

I. GOLD PROGRAM - Multiple Cumulative Purchases – WITH an Annual Fuel Quota Fuel Agreement:

- a. Discounted prices are available from gallon one (1) if the Fuel Purchaser enters into an annual contract for Multiple Cumulative Purchases – WITH an Annual Fuel Quota Fuel Agreement and is based upon the amount contracted (“Fuel Quota”). Additional discounts beyond the contracted amount are available upon reaching each successive tier level over the contracted amount stated in the Fuel Agreement – the more fuel purchased, the higher the Discount Rate.
- b. It is up to the Fuel Purchaser to notify the Fuel Seller when more than the Fuel Quota has been reached and upon reaching each successive tier level over the contracted Fuel Agreement amount. The Fuel Purchaser is to notify the Fuel Seller via the general email [hya.officemailbox@flyhya.com](mailto:hya.officemailbox@flyhya.com).



- c. See Schedule A - GOLD PROGRAM (below) for multiple cumulative purchases, using the Airport payment and credit terms.
- d. Example: For a Fuel Pricing Agreement with a Fuel Quota in the amount of 300,000 gallons, the Discount Rate from gallon one (1) would be \$0.75 per gallon. If the Fuel Purchaser actually purchased over 300,001 gallons, the Discount Rate would change to \$0.90 per gallon for all fuel purchased over 300,001 gallons.
- e. Note that any waiver of Ramp Fees must be in alignment with the Airport's published rates and charges. There is NO waiver of Airport imposed landing fees.
- f. Any aircraft wishing to participate in this program must have a prior written approved Fuel Agreement from the Fuel Seller; and for based or fleets of aircraft they must provide a list of eligible aircraft tail numbers in advance of purchases and provide a specific fuel release for each purchase.
- g. If Fuel Purchaser purchases less than the Fuel Quota from the Fuel Seller during the term of the Fuel Agreement, then Fuel Purchaser shall pay Fuel Seller a penalty ("Fuel Quota Penalty"). The Fuel Quota Penalty would be paid in addition to the previously paid Discount Rate for each gallon of fuel purchased during the term of this Agreement, a lump sum payment at the end of the term to account for the shortfall in fuel purchases. The Fuel Quota Penalty shall be calculated as follows:

Where:

Y = Gallons actually purchased by Fuel Purchaser from Fuel Seller during the term of an Agreement

Fuel Quota Penalty Rate = \$2.40/gallon

Fuel Quota Penalty = \$2.40 – the discount price per gallon x (Fuel Quota-Y)



Example:

|                                       |   |                              |
|---------------------------------------|---|------------------------------|
| Fuel Quota                            | = | 400,001 gallons              |
| Y                                     | = | 350,001 gallons              |
| Fuel Quota Not Met (in gallons)       | = | (400,001 – 350,001) = 50,000 |
| Fuel Quota Penalty Rate Per Gallon(1) | = | \$2.40                       |
| Discount Price Per Gallon             | = | \$1.10                       |
| Fuel Quota Penalty                    | = | \$2.40 - \$1.10 x 50,000     |
|                                       | = | \$65,000                     |

Notes:

(1) The Fuel Seller adds a margin per gallon to all fuel to arrive at a retail price, adjusted on a weekly basis. Because this rate is adjusted on a weekly basis and can therefore fluctuate weekly, the Fuel Quota Penalty has identified this margin as a fixed rate for ease of calculation and known quantity for any penalties implemented.

h. The Discount Rate would only change when the new tier is reached beyond the Fuel Quota, not back to gallon one.

II. SILVER PROGRAM - Multiple Cumulative Purchases – WITH/OUT an Annual Fuel Quota Fuel Agreement:

- a. Discounted prices are available and awarded only when the Gallons/Uplift (see Schedule B below - SILVER PROGRAM) is achieved if the Fuel Purchaser enters into an annual contract for Multiple Cumulative Purchases – WITH/OUT an Annual Fuel Quota Fuel Agreement. Additional discounts are available upon reaching each successive tier level – the more fuel purchased, the higher the Discount Rate once the tier level is reached.
- b. It is up to the Fuel Purchaser to notify the Fuel Seller upon reaching each successive tier level. The Fuel Purchaser is to notify the Fuel Seller via the general email [hya.officemailbox@flyhya.com](mailto:hya.officemailbox@flyhya.com).
- c. See Schedule B – SILVER PROGRAM (below) for multiple cumulative purchases, using the Airport payment and credit terms.
- d. Example: For a Fuel Pricing Agreement with/out a Fuel Quota, if the Fuel Purchaser purchases 50,000 gallons, no Discount Rate is applied. If the Fuel Purchaser purchases 100,001 gallons within the same contract year, each gallon thereafter and up to 200,000 gallons





purchased is eligible for a \$0.35 discount/gallon, the Discount Rate, (from 100,001 gallons to 200,000 gallons purchased). If the Fuel Purchaser purchases 200,001 gallons within the same contract year, each gallon thereafter and up to 300,000 gallons purchased is eligible for a \$0.50 discount/gallon (from 200,001 gallons to 300,000 gallons purchased) and so on.

- e. The Discount Rate would only change when the new tier is reached and will not apply back to gallon one.
- f. Note that any waiver of Ramp Fees must be in alignment with the Airport's published rates and charges. There is NO waiver of Airport imposed landing fees.
- g. Any aircraft wishing to participate in this program must have a prior written approved Fuel Agreement from the Fuel Seller; and for based or fleets of aircraft they must provide a list of eligible aircraft tail numbers in advance of purchases and provide a specific fuel release for each purchase.

III. BRONZE PROGRAM - Multiple Cumulative Purchases – WITH/OUT an Annual Fuel Quota Fuel Agreement (“Loyalty Program”):

- a. Discounted prices are available and awarded only when the Gallons/Uplift (see Schedule C below - BRONZE PROGRAM) is achieved if the Fuel Purchaser enters into an annual contract for Multiple Cumulative Purchases – WITH/OUT an Annual Fuel Quota Fuel Agreement - Loyalty Program.
- b. It is up to the Fuel Purchaser to enter into an annual contract for Multiple Cumulative Purchases – WITH/OUT an Annual Fuel Quota Fuel Agreement - Loyalty Program. The Loyalty Program will be administered in the following manner:
  - i. Year One (initial contract year). Fuel Purchaser must contract under the SILVER PROGRAM - Multiple Cumulative Purchases – WITH/OUT an Annual Fuel Quota Fuel Agreement
  - ii. Year Two. Based on Fuel Purchaser's ability to purchase fuel that exceeds the second tier under the SILVER PROGRAM - Multiple Cumulative Purchases – WITH/OUT an Annual Fuel Quota Fuel Agreement (100,001 gallons of



fuel purchased), the Discount Price for year Two will be available from gallon one (1).

- iii. See Schedule C - BRONZE PROGRAM (below)
- c. It is up to the Fuel Purchaser to notify the Fuel Seller upon reaching each successive tier level over the contracted amount. The Fuel Purchaser is to notify the Fuel Seller via the general email [hya.officemailbox@flyhya.com](mailto:hya.officemailbox@flyhya.com).
- d. See Schedule C – BRONZE PROGRAM (below) for multiple cumulative purchases, using the Airport payment and credit terms.
- e. Example: Multiple Cumulative Purchases – WITH/OUT an Annual Fuel Quota Fuel Agreement - Loyalty Program, if the Fuel Purchaser purchases 100,001 gallons of fuel in Year One, the Discount Rate is applied in Year Two of the Fuel Agreement from gallon one (1).
- f. Note that any waiver of Ramp Fees must be in alignment with the Airport's published rates and charges. There is NO waiver of Airport imposed landing fees.
- g. Any aircraft wishing to participate in this program must have a prior written approved Fuel Agreement from the Fuel Seller; and for based or fleets of aircraft they must provide a list of eligible aircraft tail numbers in advance of purchases and provide a specific fuel release for each purchase.



## Program Schedules

### SCHEDULE A – GOLD PROGRAM

| Tier Level | Gallons/ Uplift   | Discount/Gal | Waive Ramp Fees<br>(See Published Airport Rates and Charges) |
|------------|-------------------|--------------|--|
| 1          | 100,001 - 200,000 | \$0.60       | Yes  |
| 2          | 200,001 - 300,000 | \$0.75       | Yes  |
| 3          | 300,001 - 400,000 | \$0.90       | Yes  |
| 4          | 400,001 - 500,000 | \$1.10       | Yes  |
| 5          | 500,001 and above | TBD          | Yes  |

Sales with approved credit card or pre-approved net 10 credit/payment plan and terms

### SCHEDULE B – SILVER PROGRAM

| Tier Level | Gallons/ Uplift   | Discount/Gal | Waive Ramp Fees<br>(See Published Airport Rates and Charges) |
|------------|-------------------|--------------|--|
| 1          | 1-100,000         | \$0.00       | Yes  |
| 2          | 100,001 - 200,000 | \$0.35       | Yes  |
| 3          | 200,001 - 300,000 | \$0.50       | Yes  |
| 4          | 300,001 - 400,000 | \$0.65       | Yes  |
| 5          | 400,001 - 500,000 | \$0.85       | Yes  |
| 6          | 500,001 and above | TBD          | Yes  |

Sales with approved credit card or pre-approved net 10 credit/payment plan and terms

### SCHEDULE C – BRONZE PROGRAM

| Tier Level | Gallons/ Uplift   | Discount/Gal | Waive Ramp Fees<br>(See Published Airport Rates and Charges) |
|------------|-------------------|--------------|--|
| 1          | 1-100,000         | \$0.20       | Yes  |
| 2          | 100,001 - 200,000 | \$0.35       | Yes  |
| 3          | 200,001 - 300,000 | \$0.50       | Yes  |
| 4          | 300,001 - 400,000 | \$0.65       | Yes  |
| 5          | 400,001 - 500,000 | \$0.85       | Yes  |
| 6          | 500,001 and above | TBD          | Yes  |

Sales with approved credit card or pre-approved net 10 credit/payment plan and terms



480 Barnstable Rd, Hyannis, MA 02601 | flyHYA.com | 508.775.2020

KATIE RILEY SERVIS Airport Manager | MATTHEW T. ELIA Assistant Airport Manager

Larger annual quantity discounts for purchases exceeding 500,000 gallons may be offered and will be subject to a negotiated contract.

CAPE COD GATEWAY AIRPORT  
JET FUEL DISCOUNT PROGRAM

Effective Date: October 19, 2021

Approved by:

\_\_\_\_\_  
John T. Griffin, Jr., Chairman  
Cape Cod Gateway Airport Commission

\_\_\_\_\_  
Date



## Attachment A

### Credit and Payment Terms.

Payment by Fuel Purchaser shall be made by check or approved electronic funds transfer, and the terms shall be net ten (10) days subject to credit approval by the Fuel Seller. Past due amounts shall accrue interest at a rate of one and one-half percent (1.5%) per month, or the maximum rate permitted by applicable law, whichever is less. All amounts more than fifteen (15) days past due shall incur an additional five percent (5%) administrative fee. Any waiver by the Fuel Seller of interest charges or administrative fees on a particular invoice shall not be construed as a waiver by the Fuel Seller of its right to impose such charges on other or subsequent jet fuel sales. The Fuel Seller reserves the right to apply Fuel Purchaser's payments to any outstanding invoices or obligations of Fuel Purchaser as determined by the Fuel Seller in its sole discretion, without regard to the aging of any account. Fuel Purchaser shall be liable for all fees and costs, including without limitation attorney's fees, incurred by the Fuel Seller in connection with any collection activities undertaken by the Fuel Seller for the non-payment of any amounts due hereunder by Fuel Purchaser. The Fuel Seller reserves the right to modify or cancel the credit terms provided to the fuel customer at any time, in its sole discretion upon notice to Fuel Purchaser. If the Fuel Seller selects not to extend or cancels any credit terms provided to the Fuel Purchaser, prior to each sale of aviation jet fuel, Fuel Purchaser shall: (a) make a prepayment to Fuel Seller; (b) cause to be issued a letter of credit in favor of the Fuel Seller in a form and in an amount from a bank that is acceptable to the Fuel Seller from time to time in its sole discretion; (c) cause all Fuel Purchaser sales transactions to be by the use of a Fuel Seller approved 0% carrying charge credit card; or (d) give other security to the Fuel Seller in a manner, or a type, in a form and in an amount that is acceptable to the Fuel Seller. The Fuel Seller reserves the right, in addition to all other rights and remedies available to it under the law, in equity or otherwise, to suspend further performance of fuel sales, and demand payment of all outstanding balances, if Fuel Purchaser fails to make any payment as herein provided, or if the Airport at any time deems itself insecure with regard to the creditworthiness or financial condition of the Fuel Purchaser.



---

480 Barnstable Rd, Hyannis, MA 02601 | flyHYA.com | 508.775.2020

KATIE RILEY SERVIS Airport Manager | MATTHEW T. ELIA Assistant Airport Manager













# ROSS AVIATION

---

730 Barnstable Rd., Hyannis, MA 02601

**5** YEAR  
WARRANTY  
PARTS, LABOR  
& SIGNAGE

 **Signdedlz**<sup>LLC</sup>  
GREAT SIGNS AT GREAT PRICES

# The Signdealz Advantage



## Company History

Signdealz was born out of the great recession in 2010, from our customer's desire to purchase quality electric business signs at reasonable prices. William Hayes, the owner, re-engineered the way signs were designed, manufactured, and installed in order to lower costs and focus our efforts on what was essential to our customers.

Signdealz model incorporates several advantages to enable our process of delivering a higher level of customer service and product quality.

- **Vendor Network:** We have developed a mature network of high quality and efficient manufacturing and installation partners whom we reward for delivering excellent customer service.
- **Data Management Approach:** We focus on data. Our integrated approach includes a centralized data management platform for project financials, communication, purchasing, and project delivery. A 360-degree view in one place for all team members to see the project through its life cycle.
- **Team-Based Approach:** Every member of our team, including our customers, employees, and vendors, focus on delivering a quality product, on time, and on budget. We don't have the distraction of managing other processes that are not critical to project delivery like our competition.



## Fabrication/Installation

Signdealz created an expansive network of wholesale fabricators with virtually unlimited capabilities. Our fabrication partners offer the most state-of-the-art computerized design and manufacturing equipment staffed by some of the most experienced sign fabricators committed to consistently delivering the highest quality products at the most competitive prices in the industry. Our market-based approach to sign fabrication gives us the ability to offer more products for less money, giving you opportunities to maximize your advertising investment.

## Project Management

Project management is the core of our organization. Crafted from hundreds of sign projects over 10 years, we developed a process with one single purpose, growing happy customers! It starts the best project managers in the business. Sprinkle in state-of-the-art technology and you get that perfect recipe for project success.

## Service & Warranty

### Signdealz Warranty

Signdealz will warranty all signage products with a 5 Year parts and labor warranty. We proudly stand behind the US made products manufactured by our partner network. You can expect service calls to be carried out within a 48 hours. Some exceptions may exist with our LED Sign products based on parts availability.





# The Signdealz Team

GREAT SIGNS AT GREAT PRICES



**William Hayes : CEO**  
Portland, OR

For over 20 years, my passion has been helping any size organization develop winning B2B and B2C advertising strategies using on-premise signage solutions in conjunction with traditional advertising mediums.



**OUN: Project Strategist**  
Houston, TX

OUN has been developing, specifying, and designing signs for over 25 years. With a keen eye for great design, an innovative mind, and an unparalleled attention to detail he makes sure your project is the best solution for your needs, every time.



**Steve Scovill: Senior Project Specialist**  
Denver, CO

Steve has over a decade of sign industry experience in both the electrical and graphics industries. He brings a consultative customer driven approach to solving your signage needs.



**Priscilla Heilingoetter: Sr. Project Manager**  
Austin, TX

Priscilla entered the sign industry and has worked on a variety of accounts handling both exterior and interior signage, including Red Robin, Walgreens, CVS, Verizon, and Panera Bread. Priscilla has extensive experience handling custom projects. She was also the sole project manager on two large Northwestern Health Care Corporation projects in the Chicago area, involving the removal of existing signage and installation of over 500 signs.



**Aubree Daugherty : Assistant Project Manager**  
Houston, TX

As an assistant Project Manager, I enjoy using my skills to contribute to the exciting Signage world that happens every day at Signdealz. I have learned a lot from the past year and I look forward to keeping growing in this industry until I become a Senior Project Manager.



**Amber Daugherty: Sr. Project Manager**  
Houston, TX

Amber has a passion for helping customers through the complicated maze of permits, design requirements, and project contracts. She has an eye for detail and enjoys developing lasting relationships with our customers. She has over 13 years of experience in the sign industry.



**Gio Smith : Finance/HR**  
Greely, CO

Gio is a critical part of our team DNA. With over 12 years of administrative experience at the C level, she works with our clients through various issues to include billing issues, invoicing, and insurance.



**Troy Huscher: Design Director**  
Branford, CT

Troy is an award winning sign designer with over 20 years experience in sign design with an emphasis on national brand implementation & creative design solutions. Troy has created corporate identity standards for many Fortune 500 companies in the USA including Edible Arrangements & Charter Oak Credit Union.



**Ritesh Mistry: CTO**  
New York, NY

He has over 8 years of purchasing, estimating, and project management experience. He makes sure our subcontractors know the full scope of work and that we fully communicate the level of quality our customers expect.

Building ID Sign: Front Elevation

**SIGN 1**

92"

52.5"

# RA&

**Fabrication Specs**

Non illuminated fabricated aluminum channel letters  
 Aluminum faces & 2" deep returns painted PMS 7655C Blue  
 Flush mounted to wall

Remove & scrap existing sign

All sizes to be verified with tech survey prior to production



**CL Flush Mount Attachment Method Specifications:**  
 Hardware Type: 3/8" All Thread  
 Hardware Length: 6" to 8"  
 Approximate Number of fasteners and Position: 6 per letter



Existing Sign: Remove & Scrap



Newly Proposed Signage



**Connection Specifications**  
 Attach letters to wall with Evenly Spaced Connectors. See Drawings for Complete Fabrication Specifications. Use Oversized Washer Backers for thru Wall Connections.

| CONNECTION QUANTITY | 3/8" ALL-THREAD |
|---------------------|-----------------|
| LETTERS (EACH)      | 6               |

All Thread with Nuts and Washers

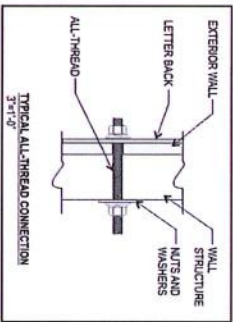

**M MacFarland**  
 111 E. Duane St.  
 Melrose, MA 02128  
 781-326-1111  
 macfarland@macfarland.com  
 www.macfarland.com

**ROSS AVIATION**  
 Address: 730 BARNSTABLE RD  
 CHATHAM, MASSACHUSETTS, MA  
 Client: SIGNDEALZ

ENGINEERING OF  
 ATTACHED TO WALL ONLY  
 NO CABINET ENGINEERING  
 OR EVALUATION OF AS  
 BUILT WALL CONDITIONS  
 PROVIDED OR SUPPLIED.

Initial Drawing: \_\_\_\_\_ \$3995.00  
 \_\_\_\_\_  
 \_\_\_\_\_



For Reference and Information Only - Not for Construction  
 Approved Date: 8/14/2017  
 Date: 8-31-2021  
 Sheet #: 1 OF 3  
 MCFarm Engineers, P.C.  
 Massachusetts License Number: 45941  
 Massachusetts Expiration Date: 8/31/2022

**Signdedalz**  
 1644 Platte St.  
 Denver, CO 80202  
**PHONE: 1-800-405-0686**

CUSTOMER NAME: Ross Aviation  
 PROJECT NAME: Exterior Signage  
 LOCATION: 730 Barnstable Rd., Hyannis, MA 02601  
 OPPORTUNITY / P.O. NO. (1): OP-SS-004492  
 DATE: 9/1/21  
 SALES: Steve Scovill

DESIGNER: TH  
 APPROVAL: \_\_\_\_\_  
 Customer Signature (legible)  
 Approval Date: \_\_\_\_\_

**5 YEAR WARRANTY**  
 ALL PARTS LABOR & SIGNAGE

THIS IS AN ORIGINAL DESIGN / DRAWING CREATED BY SIGNDEALZ CORPORATION AND REMAINS THE PROPERTY OF SIGNDEALZ CORPORATION UNTIL TRANSFER BY SALE. ALL RIGHTS RESERVED. ANY UNAUTHORIZED USE OR DUPLICATION WILL RESULT IN \$1000 FINE. COPYRIGHT 2011-2017 SIGNDEALZ.COM

Blade Sign: Double Sided

**SIGN 2**

36"

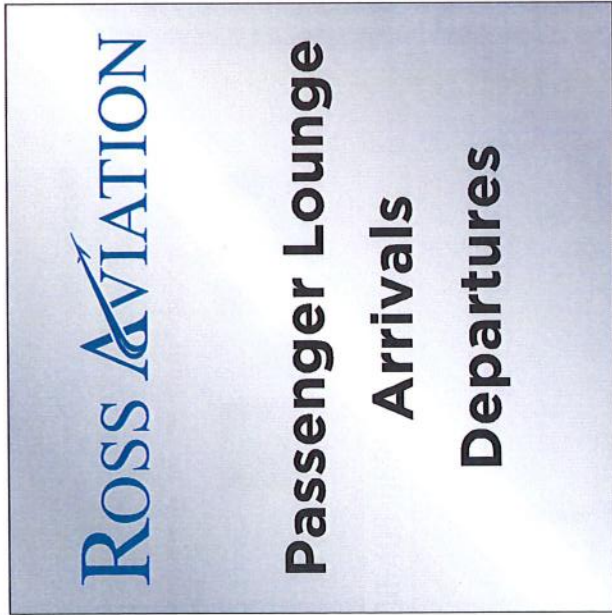

36"

Newly Proposed Signage



Existing Sign



**Fabrication Specs**

New .125" thick aluminum face painted MAP brushed aluminum  
3M HP Electric blue & 3M HP black vinyl graphics

All sizes to be verified with tech survey prior to production



**Signdealz**  
 Signdealz  
 1644 Platte St.  
 Denver, CO 80202

**PHONE: 1-800-405-0686**

CUSTOMER NAME: Ross Aviation

PROJECT NAME: Exterior Signage

LOCATION: 730 Barnstable Rd., Hyannis, MA 02601

OPPORTUNITY / P.O. NO.(S): OP-SS-004492

DATE: 9/1/21

SALES: Steve Scovill

DESIGNER

TH

PAGE 5

APPROVAL:

Customer Signature (legible)

(X)

Approval Date:

**5** YEAR WARRANTY  
 PARTS, LABOR & SIGNAGE

Monument Sign: Single Sided

**SIGN 3**

96"

36"



Newly Proposed Signage

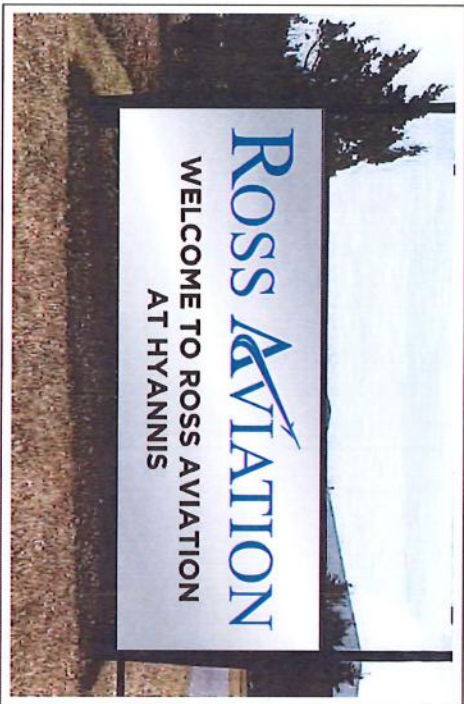

Existing Sign



**Fabrication Specs**  
 New: .125" thick aluminum face painted MAP brushed aluminum  
 3M HP Electric Blue & 3M HP black vinyl graphics  
**All sizes to be verified with tech survey prior to production**



**Signdedalz**  
 1644 Platte St.  
 Denver, CO 80202

**PHONE: 1-800-405-0686**

|   |                      |
|---|----------------------|
| CUSTOMER NAME: Ross Aviation                    |                      |
| PROJECT NAME: Exterior Signage                  |                      |
| LOCATION: 730 Barnstable Rd., Hyannis, MA 02601 |                      |
| OPPORTUNITY / NO. INQUIRY: OP-SS-004492         | SALES: Steve Scovill |
| DATE: 9/1/21                                    |                      |

|              |
|--------------|
| DESIGNER: TH |
| PAGE 6       |

|                              |
|------------------------------|
| APPROVAL:                    |
| Customer Signature (legible) |
| (X)                          |
| Approval Date:               |



THIS IS AN ORIGINAL DESIGN / DRAWING CREATED BY SIGNDEDALZ CORPORATION AND REMAINS THE PROPERTY OF SIGNDEDALZ CORPORATION UNTIL TRANSFER BY SALE. ALL RIGHTS RESERVED. ANY UNAUTHORIZED USE OR DUPLICATION WILL RESULT IN \$1000 FINE. COPYRIGHT 2011-2017 SIGNDEDALZ.COM



Monument Sign: Single Sided

**SIGN 4**

36"



48"

Newly Proposed Signage



**Fabrication Specs**

New .125" thick aluminum face painted MAP brushed aluminum  
3M HP Electric blue & 3M HP black vinyl graphics

All sizes to be verified with tech survey prior to production



**Signdedalz**  
1644 Platte St.  
Denver, CO 80202

**PHONE: 1-800-405-0686**

CUSTOMER NAME: Ross Aviation  
PROJECT NAME: Exterior Signage  
LOCATION: 730 Barnstable Rd., Hyannis, MA 02601  
OPPORTUNITY / A.G. NO: OP-SS-004492  
DATE: 9/1/21

SALES: **Steve Scovill**

DESIGNER: TH  
PAGE 7

APPROVAL: \_\_\_\_\_  
Customer Signature (legible)

(X)

Approval Date: \_\_\_\_\_

**5 YEAR WARRANTY**  
**ALL PARTS, LABOR & SIGNAGE**

ME #: 53695

Main ID Sign

SIGN 5

42'-7"

# ROSS AVIATION

72" 58.5"

**Fabrication Specs:**

- 5" Deep face lit LED channel letters mounted to custom 12" aluminum raceways
- 3/16" White acrylic faces with 3M 3530-27 electric blue translucent vinyl
- 1" Trim cap & 5" deep aluminum returns painted PMS 7685C blue
- Internally illuminated with white LEDs

Remove & Scrap existing signs

All sizes to be verified with tech survey prior to production



**Channel Letter Electrical Specifications:**

Who Makes Electrical Connection: GC  
 Power Requirement: 120V 3 AMP - 20 Amp Dedicated Circuit

CL Flush Mount Attachment Method Specifications:  
 See following sheet for connector options

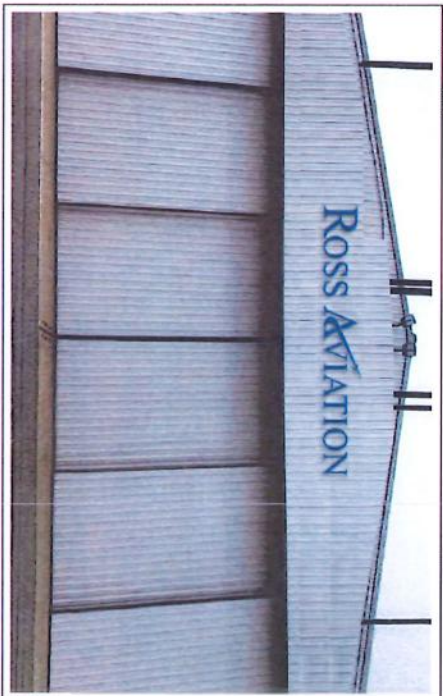
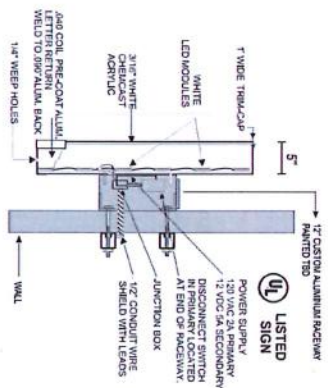

Newly Proposed Signage

**M** Medford  
 141 Lakeview Ct  
 Medford, NJ 07643  
 Tel: 973-261-2200  
 Fax: 973-261-2201  
 Email: sales@medford.com  
 Web: www.medford.com

**ROSS AVIATION**  
 Address: 720 BARNSTABLE RD  
 CHESHIRE HYANNIS, MA  
 Client: SIGNEALZ

ENGINEER OR  
 ARCHITECT TO SEAL ONLY  
 NO OTHER ENGINEERING  
 OR ELECTRICAL CONDITIONS  
 PROVIDED OR IMPLIED

Initial Drawing: \_\_\_\_\_ (53695) 05  
 \_\_\_\_\_  
 \_\_\_\_\_  
 \_\_\_\_\_



The information appearing on this drawing was  
 prepared by me or under my direct supervision and  
 I am a duly Licensed Professional Engineer in the  
 State of New Jersey.  
 Date: 8-31-2021  
 Sheet #: 2 OF 3  
 ICFM Register #: 1535  
 License Number: 4811  
 My Expiration Date: 08/31/2022

**Signdeadlz**  
 1644 Platte St.  
 Denver, CO 80202  
 PHONE: 1-800-405-0686

**CUSTOMER NAME:** Ross Aviation  
**PROJECT NAME:** Exterior Signage  
**LOCATION:** 730 Barnstable Rd, Hyannis, MA 02601  
**OPPORTUNITY / P.O. NUMBER:** OP-SS-004492  
**DATE:** 9/1/21  
**SALES:** Steve Scovill

**DESIGNER:** TH  
**APPROVAL:** \_\_\_\_\_  
 Customer Signature (legible)  
**PAGE 8**  
 Approval Date: \_\_\_\_\_

**5 YEAR WARRANTY**  
 ALL PARTS, LABOR & SIGNAGE

THIS IS AN ORIGINAL DESIGN / DRAWING CREATED BY SIGNEALZ CORPORATION AND REMAINS THE PROPERTY OF SIGNEALZ CORPORATION UNTIL TRANSFER BY SALE. ALL RIGHTS RESERVED. ANY UNAUTHORIZED USE OR DUPLICATION WILL RESULT IN \$1000 FINE. COPYRIGHT 2011-2017 SIGNEALZ.COM

ME #: 53695

**Connection Specifications**  
 Attach Channel Letter Raceway to Wall with Evenly Spaced Connectors. See Drawings for Complete Fabrication Specifications. Don't Over-tighten Connectors. Use UNISTRUT Backers for Thru Wall Connectors. See Schedule for Letter Attachment Quantity to Raceway. Divide All Connectors Proportionately Between Raceways.

| CONNECTION QUANTITY | ①  | ②  | ③  | ④  |
|---------------------|----|----|----|----|
| TOTAL RACEWAYS      | 24 | 24 | 24 | 24 |
| LETTER "H"          |    |    | 8  | 10 |
| LETTER "M"          |    |    | 12 |    |
| OTHER LETTERS (EA)  |    |    | 6  | 10 |

Liberty Bolt is Connected Into Thru Bolt Requires Unistrut or Poly Backer  
 \*Ross' Raceway Requires (6) (B) Connectors  
 \*Aviation' Raceway Requires (16) (16) Connectors

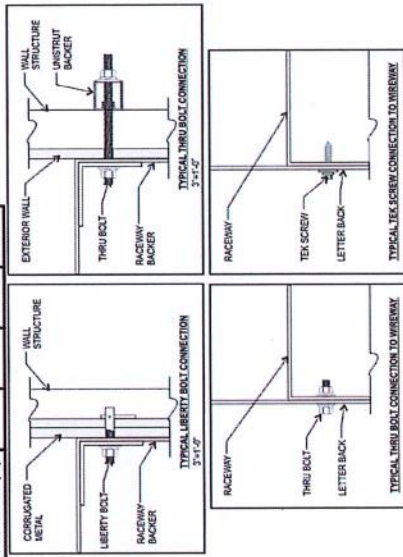

The electronic drawing on this document was automatically generated by the software.  
 Date: 8-31-2021  
 Sheet #: 3 OF 3  
 NC Firm Registration #: F-118  
 Manufacturer's License Number: 45845  
 Manufacturer's Expiration Date: 5/30/2022



Full Drawing: 53695.DWG

ENGINEERING OF ATTACHMENT TO WALL ONLY. NO CABINET ENGINEERING. ALL ELECTRICAL CONNECTIONS PROVIDED OR IMPLIED.

**ROSS AVIATION**  
 Address: 730 BARNSTABLE RD.  
 CHATHAM, MASSACHUSETTS 01949  
 Client: SIGNDEALZ

Pk: (281) 813-7439  
 Email: sales@signdealz.com  
 Web: www.signdealz.com

**5 YEAR WARRANTY**  
 PARTS, LABOR & SIGNAGE

**APPROVAL:**  
 Customer Signature (legible)  
 (X)  
 Approval Date:

DESIGNER: TH  
 PAGE 8

CUSTOMER NAME: Ross Aviation  
 PROJECT NAME: Exterior Signage  
 LOCATION: 730 Barnstable Rd., Hyannis, MA 02601  
 OPPORTUNITY / A.O. NO. (O): OP-SS-004492  
 DATE: 9/1/21

**Signdealz**  
 1644 Platte St.  
 Denver, CO 80202  
**PHONE: 1-800-405-0686**

Newly Proposed Signage:

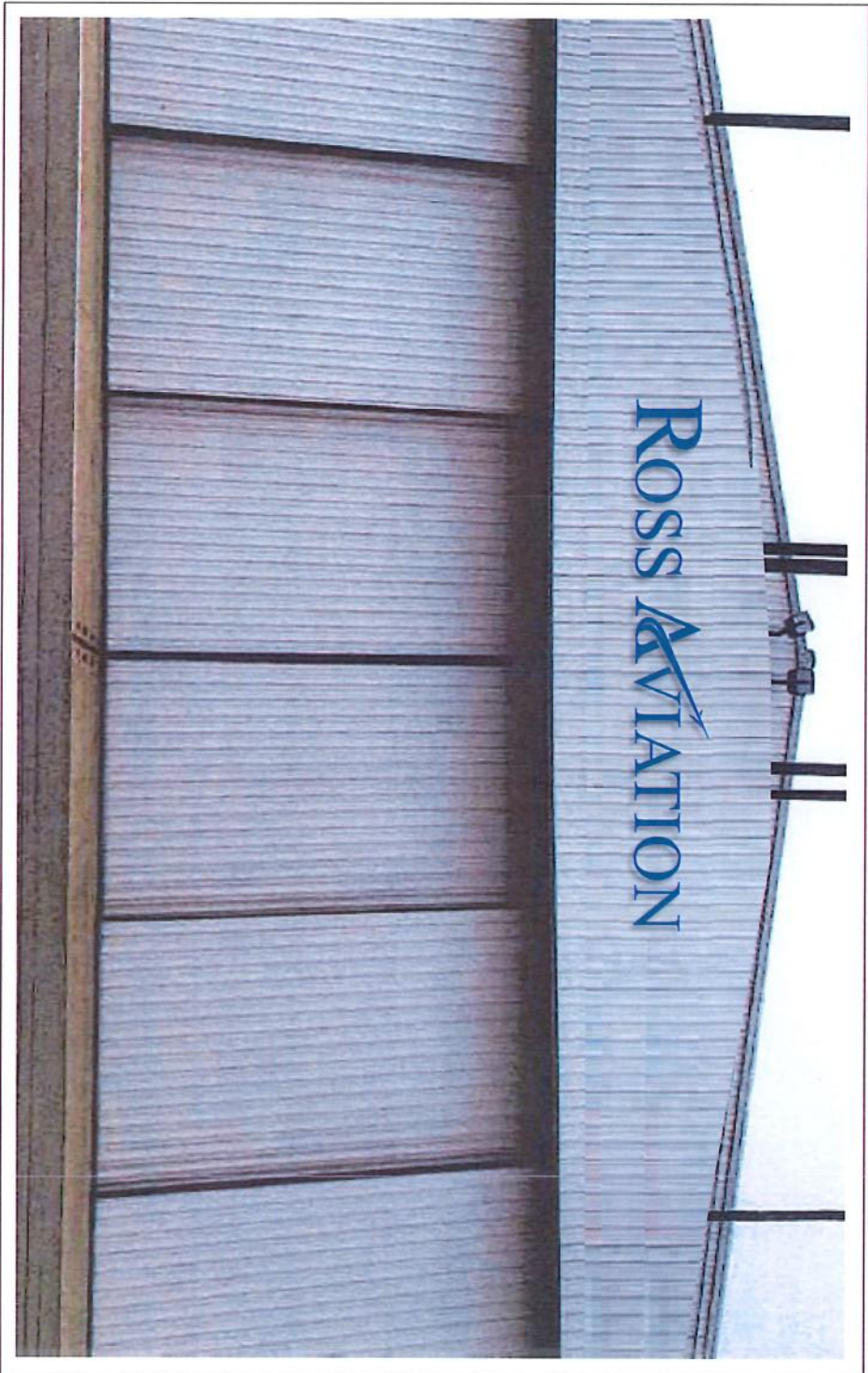

**Signdedalz**  
 1644 Platte St.  
 Denver, CO 80202

**PHONE: 1-800-405-0686**

**CUSTOMER NAME:** Ross Aviation  
**PROJECT NAME:** Exterior Signage  
**LOCATION:** 730 Barnstable Rd., Hyannis, MA 02601  
**OPPORTUNITY / PO NUMBER:** OP-SS-004492  
**DATE:** 9/1/21  
**SALES:** Steve Scovill

**DESIGNER:** TH  
**PAGE 9**

**APPROVAL:**  
 Customer Signature (legible)  
 (X)  
 Approval Date:



Main ID Sign

**SIGN 5**

Newly Proposed Signage: Night View

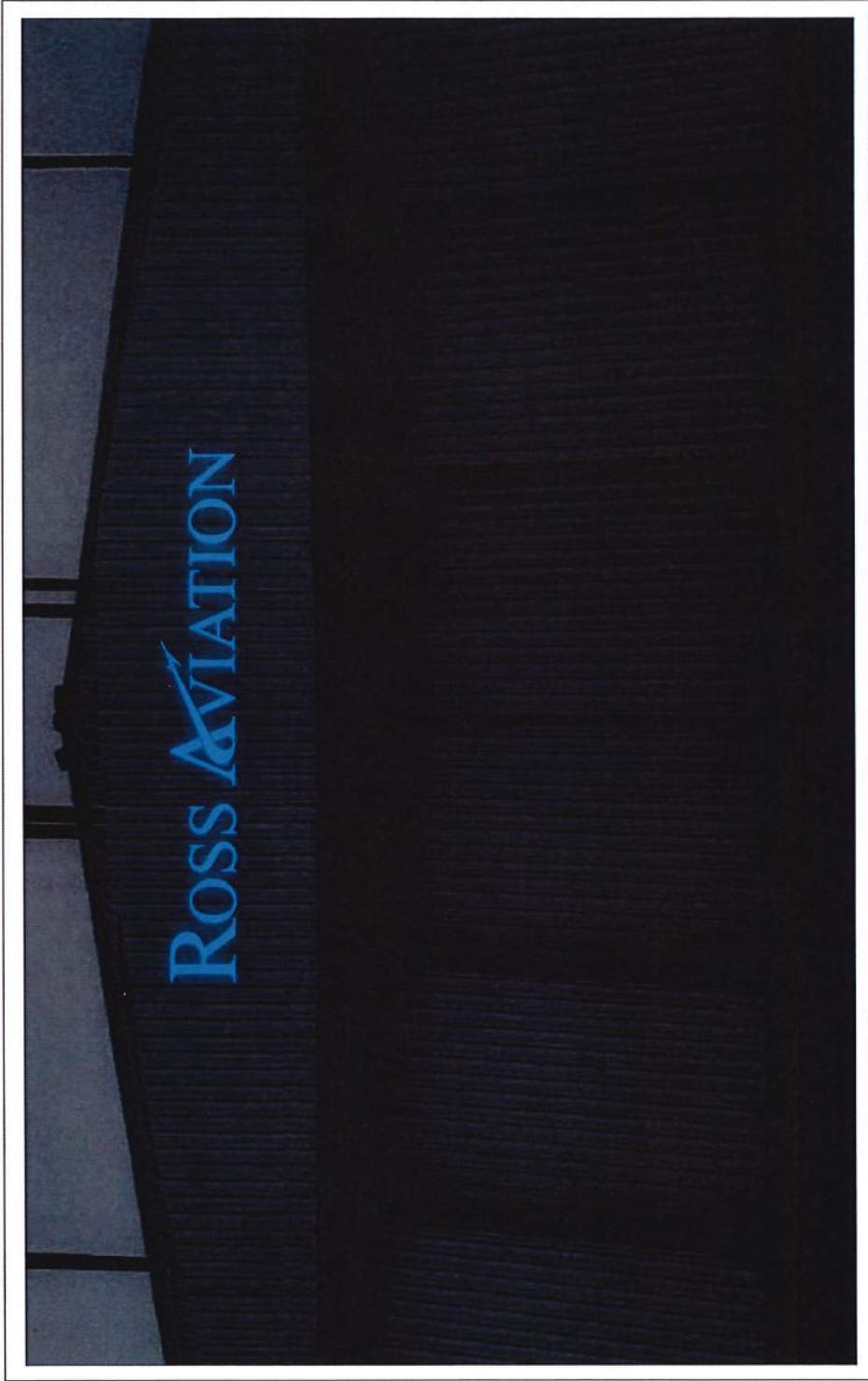

**Signdealz**  
1644 Platte St.  
Denver, CO 80202  
**PHONE: 1-800-405-0686**

CUSTOMER NAME: Ross Aviation  
PROJECT NAME: Exterior Signage  
LOCATION: 730 Barnstable Rd., Hyannis, MA 02601  
OPPORTUNITY / P.O. NO: OP-SS-004492 | SALES: Steve Scovill  
DATE: 9/1/21

DESIGNER  
TH  
PAGE 10

APPROVAL:  
Customer Signature (legible)  
(X)  
Approval Date:

**5** YEAR WARRANTY  
**ALL** PARTS, LABOR & SIGNAGE

THIS IS AN ORIGINAL DESIGN / DRAWING CREATED BY SIGNDEALZ CORPORATION AND REMAINS THE PROPERTY OF SIGNDEALZ CORPORATION UNTIL TRANSFER BY SALE. ALL RIGHTS RESERVED. ANY UNAUTHORIZED USE OR DUPLICATION WILL RESULT IN \$1000 FINE. COPYRIGHT 2011-2017 SIGNDEALZ.COM

Main ID Sign

SIGN 5

Existing Signs: Remove & Scrap



**Signdealz**

Signdealz  
1644 Platte St.  
Denver, CO 80202

**PHONE: 1-800-405-0686**

CUSTOMER NAME: Ross Aviation  
 PROJECT NAME: Esthetic Signage  
 TAGARTON: 730 Barnstable Rd., Hyannis, MA 02601  
 OPPORTUNITY / P.O. NO.: OP-SS-004492 SALES: Steve Scovill  
 DATE: 9/1/21

DESIGNER: TH  
 PAGE 11

APPROVAL:  
 Customer Signature (legible)  
 Approval Date:

**5** YEAR  
 WARRANTY  
 ALL PARTS, LABOR  
 & SIGNAGE

THIS IS AN ORIGINAL DESIGN / DRAWING CREATED BY SIGNDEALZ CORPORATION AND REMAINS THE PROPERTY OF SIGNDEALZ CORPORATION UNTIL TRANSFER BY SALE. ALL RIGHTS RESERVED. ANY UNAUTHORIZED USE OR DUPLICATION WILL RESULT IN \$1000 FINE. COPYRIGHT 2011-2017 SIGNDEALZ.COM

**CUSTOMER (ONLY)**

Color Disclaimer Note

By Initialing this Box, Customer "Agrees" that He/She "Approves" of the following Colors and Materials specifications listed. Customer "Agrees" that Signdealz is "not" responsible for Color Accuracy if Physical Samples have "not" been provided. It is the Customers responsibility to Request Physical Samples.

**COLORS & MATERIALS**



**LIGHTING**  
White LED's

**APPROVAL OF COLOR(S) & MATERIAL(S):**

Customer Initials:

Approval Date:

**CUSTOMER (ONLY)**

Electrical Disclaimer Note:

Unless otherwise Noted in Contract, Electrical "Runs" or Final Electrical Connection Charges are not included. Illuminated Displays are Wired for 120V unless otherwise indicated on Drawing.

Electrical Disclaimer Acknowledgement

Customer Initials:

Approval Date:

**LANDLORD/MANAGEMENT (ONLY)**

Landlord / Mgmt. Approval Required:

As the Manager / Landlord / Homeowners Association Representative / Owner of the above mentioned property, I (we) represent that I (we) have the authority to sign this Approval Authorization and hereby do "Authorize" installation of Outdoor Signage at the above-mentioned address by Signdealz, Inc. of their authorized subcontractor. I (we) have reviewed the Sign Specification package, and "Approve" the modifications to the property listed on the Sign Specifications package.

Landlord / Mgmt. Initials:

Approval Date:

Landlord / Management:

Print Name:

Address:

Phone:

Email:



**PHONE: 1-800-405-0686**

CUSTOMER NAME: Ross Aviation  
 PROJECT NAME: Exterior Signage  
 LOCATION: 730 Barnstable Rd., Hyannis, MA, 02601  
 OPPORTUNITY / P.O. NO: OP-SS-004492  
 SALES: Steve Scovill  
 DATE: 9/1/21

DESIGNER: TH  
 PAGE 12

APPROVAL: Customer Signature (legible)  
 Approval Date:

**INSTALLER NOTES**

